

LSENS-R Fiber Optic Temperature Sensors

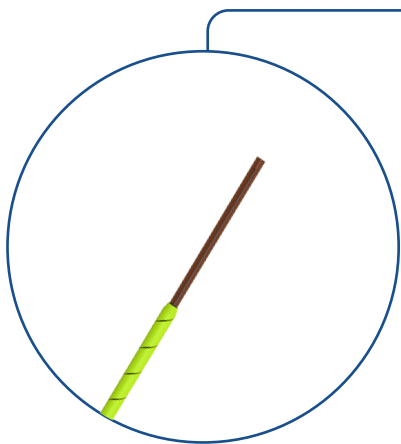

A multiuse fiber optic temperature sensor designed for a wide range of applications, especially for the use in demanding applications. The sensor offers complete immunity to RFI, EMI, NMR and microwave radiation.

The standard temperature sensor has a response time of 0.2 s. With a standard deviation of +/-0.2 °C it allows for precise and repeatable measurements. The coating of the temperature sensor is made of PTFE, and the fiber tip has a diameter of 1.7 mm with Rugged Polyimide coating and has a stainless steel ST-connector. For mechanical stability and applications e.g. in oil special protective coatings and hoses are available. The fiber optic probe consists of a PTFE protected glass fiber and a GaAs-crystal (Gallium Arsenide) at the sensor tip. It is totally free of metal and immune to external fields, therefore probes are explicitly suitable for the use in high temperature ranges as well as in aggressive operating environments. The sensor cable can be from several meters to kilometers long without influencing the accuracy of the measurement result. Other sensor lengths and connector types are available upon request.

Features

- Industrial use with rigid polyimide tip, 1.7 mm diameter
- Rugged tip ideal for industrial application
- Complete immunity to EMI/RFI/lightning
- High vibration environments

Applications

- Industrial process control and monitoring applications
- High voltage environments
- Harsh and Hazardous environments
- Industrial process control and monitoring applications
- High voltage environments
- Harsh and Hazardous environments

Benefits

- Sensors do not require any recalibration
- No shift over time, high stability
- Robust packaging
- Each sensor comes with a complete test certification

- Sensors do not require any recalibration
- No shift over time, high stability
- Robust packaging
- Each sensor comes with a complete test certification

Ordering Code

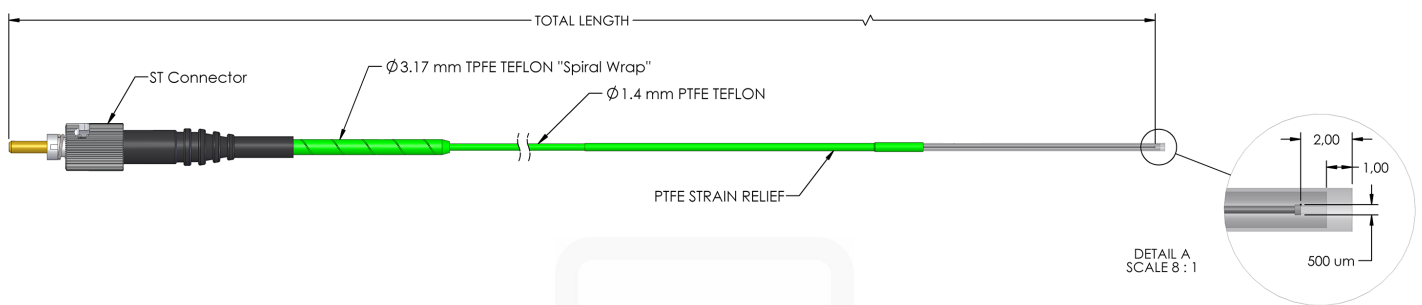
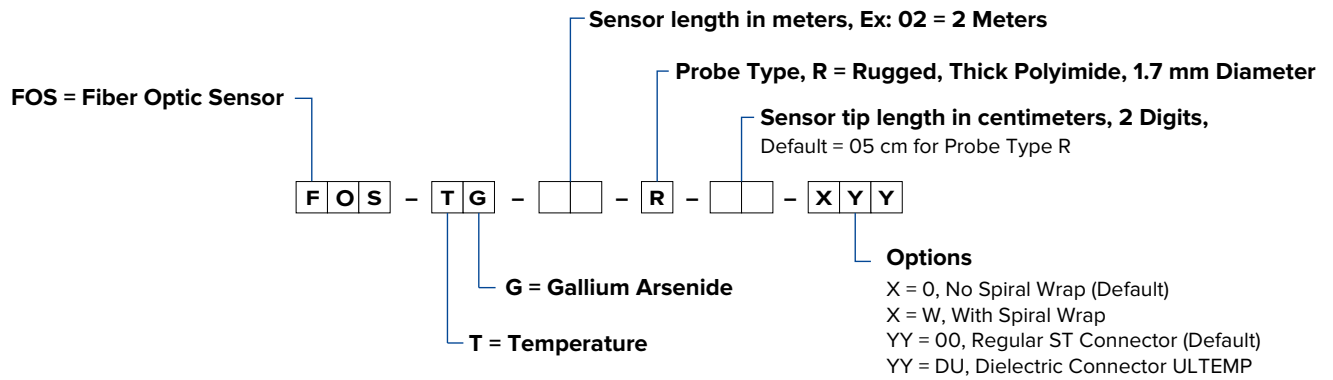

Technical Specifications

Temperature range	-200 °C to +250 °C
Temperature range (Optional Range extensions)	Down to 4 °K / Up to +300 °C
Repeatability	0.2 °C
Accuracy absolute temperature	+/- 0.8 °C
Accuracy relative temperature	+/- 0.2 °C
Probe sheathing material	Teflon Coated, Rugged Polyimide protection for sensor tip
Connector	Stainless Alloy / Optional - Dielectric
Response time	Up to 0.2 Sec
Probe sensitive area - Diameter	1.7 mm Diameter
Longevity	Probe accuracy & repeatability constant over time