



# GSENS2

## ONLINE OIL ANALYSIS



Provides highly accurate information about the abnormalities in the oil and to ensure the best health condition in transformers.

# GSENS2 Online Oil Analysis



**Provides highly accurate information about the abnormalities in the oil and to ensure the best health condition in transformers.**

Maintenance of Transformer has evolved over the years from a necessary item of expenditure to a strategic tool in the management of electrical transmission and distribution networks.

Determination of fault gases, moisture in oil and oil temperature of transformer insulating oil in the gas concentration is very important. By accurately monitoring the condition of the oil, any sudden faults can be identified, and outages can potentially be avoided. Leading to an efficient approach to maintenance and the optimum intervals can be determined for replacement.

Based on the core technology GSENS2 is a lower cost alternative, monitoring key gases: Hydrogen, Carbon Monoxide (in ppm) plus moisture in oil (%RH & ppm) as an option and Oil Temperature. The measurement of these gases allows the user to detect a wide range of developing faults including arcing.

We at Rugged Monitoring are motivated to provide innovative and exceptional quality products, our vision remains focused on meeting customer requirements while anticipating and exceeding the needs of a continuously changing dynamic market.

## Features

- Provides the ability to identify fault type
- Detection of potential failures before any fault occurs
- Prolongation of service intervals and with this, enhancement of working hours
- No calibration required
- Early indication of incipient faults
- Establish baseline data for evaluation

## Benefits

- Extended transformer life
- Minimize the need for internal inspections
- Simple and quick installation
- Less maintenance
- Mitigate the Risk and Potential for any catastrophic failures
- Easy to mount on the operating transformer without any operational interruption
- Advanced software with intuitive operation

## Measurement

Application	Determination of the gas concentration of fault gases as well as moisture in oil and oil temperature of mineral-based transformer insulating oil in accordance with IEC 60296:2012 /ASTM D3487-09				
Measured Values	H2	CO	Humidity		Oil temperature
			relative display can be switched	absolute display can be switched	
Lower Detection Limit	15 ppm	25 ppm	3% RH	5 ppm	-20°C
Upper Detection Limit	2000 ppm	2000 ppm	90% RH	2000 ppm	+115 °C
Measuring Accuracy	±10 % <sup>1,2</sup> or 3 ±20 ppm	±15 % <sup>1,2</sup> or 3 ±20 ppm	±2 %RH <sup>5</sup>	±2 % <sup>4</sup>	±1 °C
Repetition Accuracy	±5 % <sup>2</sup> or 3 ±10 ppm	±5 % <sup>2</sup> or 3 ±10 ppm	±1 %RH	±1 % <sup>4</sup>	±1 °C
Sensor resolution	1 ppm	1 ppm	1 % RH	NA	1 °C

## Conditions of use

Locations of use	Indoors and outdoors, all climate zones
Installation altitude	Up to 4,000 m above MSL
Offshore	Optional
Mounting location	Directly on the transformer tank or in the oil closed circuit cooling pipe; installation horizontal
Ambient temperature during operation <sup>6</sup>	-40...+60 °C
Oil temperature during operation <sup>6,7</sup>	-20...+115 °C
DGA measuring range with respect to the ambient temperature <sup>6</sup>	-20...+60 °C
DGA measuring range with respect to the oil temperature <sup>6,7</sup>	+10...+90 °C
Ambient humidity	0...100 %RH
Ambient temperature storage/transport	-40...+80 °C

<sup>6</sup> Please contact RM to check the use in case of extreme conditions

<sup>7</sup> At the point of measurement

## Device Properties

Mechanical connection	Via ball valve and configurable flange DN50 or DN80 (several flanges available); with safety chain for safe installation and removal
Measuring pipe length	Two different lengths for optimum measuring conditions. Short measuring pipe: 285 mm Long measuring pipe: 507 mm
Oil extraction connection	Luer lock socket on the device. adapter set for safe and clean oil extraction included in the scope of delivery
Operation	Optional VFD display (suitable for use in daylight) with 3 operating keys for displaying measured values and messages as well as for calling up parameters
Materials used	Stainless steel and aluminum. all external parts and parts in contact with oil are weather resistant, resistant to transformer oil and UV-resistant
Gasket material	FPM (VitonR)
Available colors (terminal box)	RAL 7033 RAL 7038

## GSENS2 – Oil Analysis

<b>TECHNICAL DATA</b>	Degree of protection	IP 66
	Dimensions	435 / 657 x 218 x 264 mm (version with short / long measuring pipe)
	Device weight	Version with short measuring pipe: approx. 12 kg Version with long measuring pipe: approx. 14 kg (Without ball valve / flange / safety chain)
	Ball valve weight	Approx. 6 kg (including flange and safety chain)
<b>ELECTRICAL CONNECTION</b>	Voltage Supply	95...280 V AC, 50/60 Hz or 95...280 V DC (protected against polarity reversal)
	Power Consumption	< 13 W
	Over Voltage Category	III
	Connection Terminals	Voltage supply, relays and analog outputs: 2.5 mm <sup>2</sup> , AWG 14
	Cable Gland	3 x M20 x 1.5 or 3 x 1" NPT; 8...15 mm lead diameter
<b>INTERFACES</b>	Relay Outputs	4 freely configurable signaling relays (1 changeover contact each) for warning and alarm messages and for maintenance messages from the device-internal monitoring. 1 signaling relay for safety messages (e.g., loss of voltage) Contact current capacity: 250 V AC / 5 A; max. 400 V AC, cos φ = 1 at 85 °C; 30 V DC / 5 A to 300 V DC / 0.25 A
	Analog outputs	Passive, signal tolerance 0.03 mA, load resistance max. 700 Ω at 24 V DC GSENSE DGA 200: 2 configurable outputs, 4...20 mA
	Service interface	5-pole socket (Molex) for communication via Modbus RTU and parameterization via MSET parameterization software
<b>PARAMETERIZATION SOFTWARE</b>	Delivery	On USB stick, included in the GSENSE2 scope of delivery
	Operating system	Microsoft Windows 7 8 and up
	Measured value display and evaluation	Display of the current measured values and device information. Event database with time stamp (date and time); graphic display and evaluation of the temporal progression of the measured values. Export of the measured values (CSV file) or settings of a protocol (PDF file)
	Parameterization	Configuration of the parameters for commissioning, communication, and ongoing operation
	Adjustment	Setting the time stamp of the oil sample extraction. Entry of the reference values in accordance with the laboratory report
	Service	Reading out the internal device service database for further analysis by RM experts
<b>MECHANICAL TESTS</b>	Vibration	10-150 Hz at 2 g, 2 h (IEC 60068-2-6)
	Earthquake	2-10 Hz, 22.5 mm, 1 h (IEC 60068-2-57)
	Shock	10 g, 10 ms (IEC 60068-2-27)



## GSENS2 - Oil Analysis Dimensions

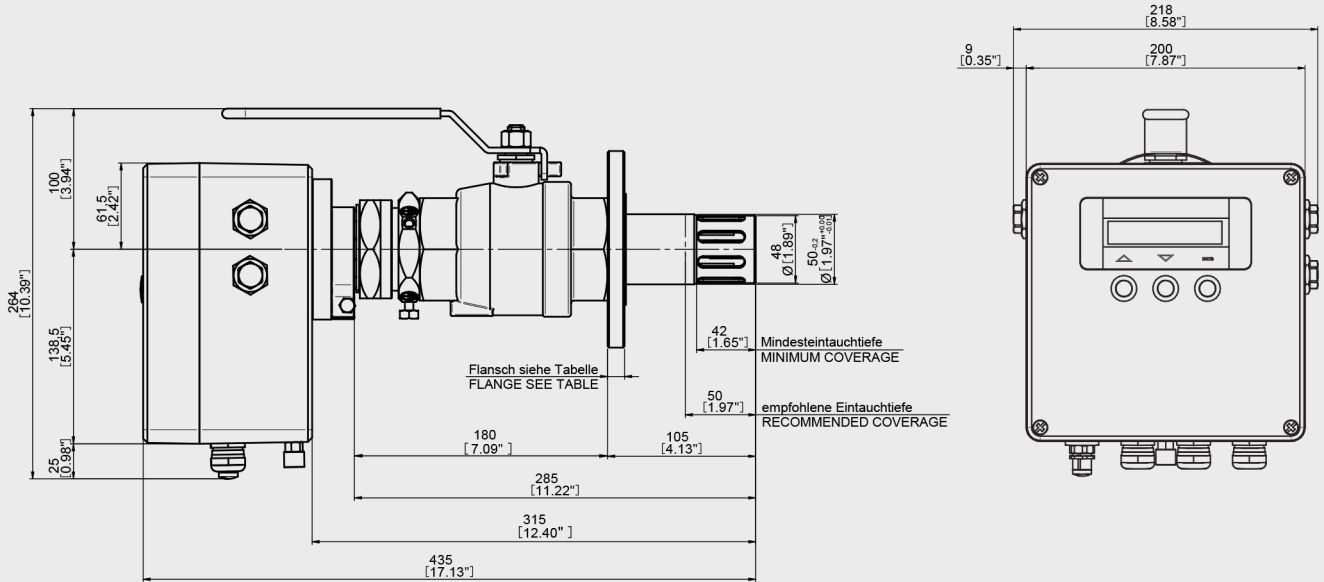

## GSENS2 - Oil Analysis Electrical Connection

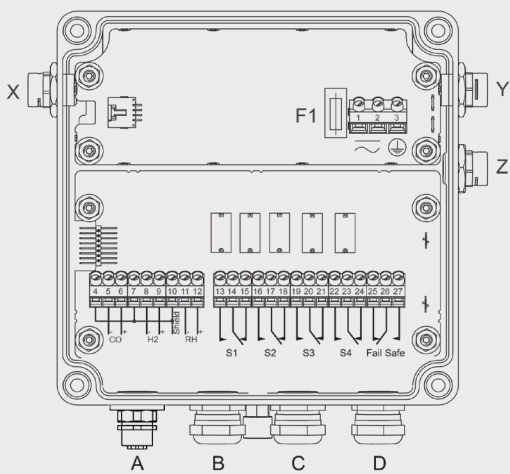
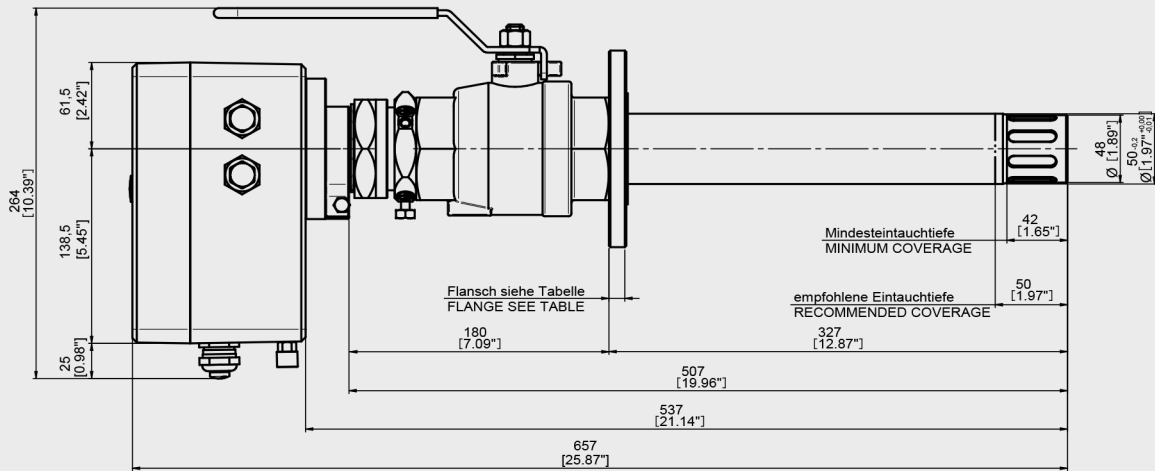

1-2	Supply voltage (overvoltage category III) 95...280 V AC 50/60 Hz or 95...280 V DC (any polarity)
3	Protective conductor
4-12	Analog outputs 4...20mA passive (must be supplied with 24 V DC)
13-27	Main switching contacts (crossovers for state signaling) capacity: 30 V DC / 5 A to 300 V DC / 0.25 A or 250 V AC / 5 A; max. 400 V AC, cos φ = 1 at 85 °C
F1	Safety fuse 500 V, 500 mA, delayed action
A	M12 socket, type A for Modbus RTU (RS485) and for USB service adapter (included in delivery)
B	M20x1.5 cable screw connection for analog outputs
C	M20x1.5 cable screw connection for signaling relay
D	M20x1.5 cable screw connection for supply voltage
X, Y, Z	Vents

# GSENS2 – FLANGES DIMENSIONS

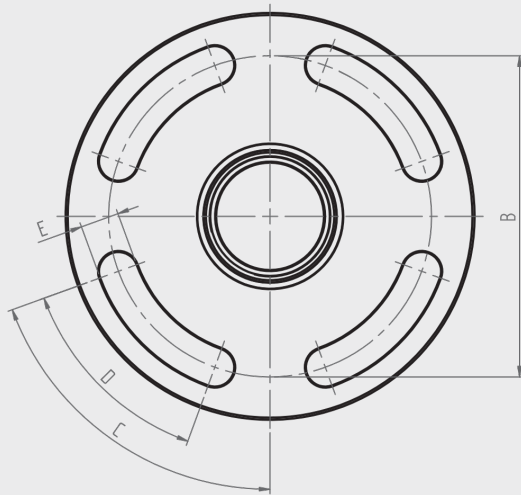

Dimensions see page 7

for O-ring seal\*)

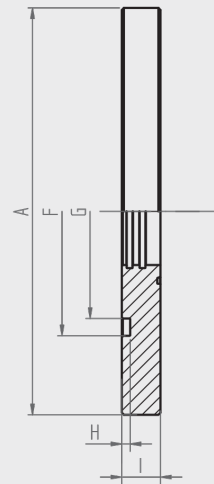

\*) O-ring seal included in scope of delivery

for any seal\*\*)

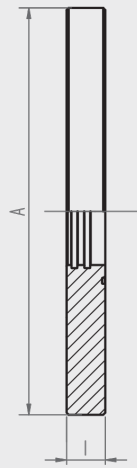

\*\*) No seal in scope of delivery

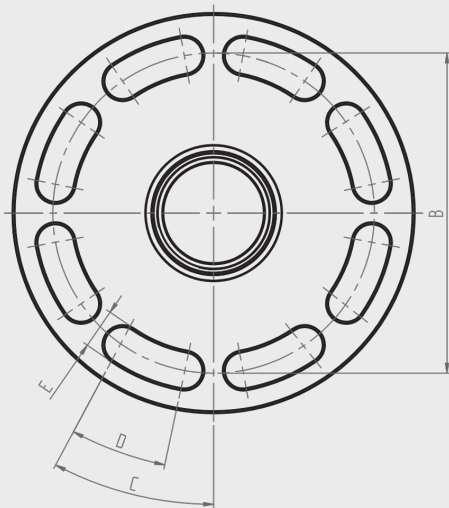

Dimensions see page 7

for O-ring seal\*)

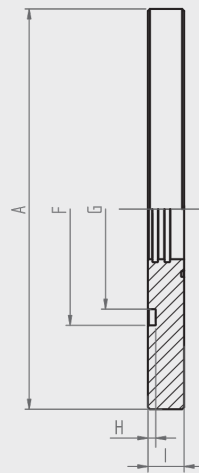

\*) O-ring seal included in scope of delivery

for any seal\*\*)

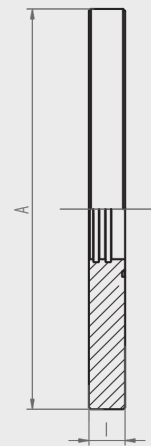

\*\*) No seal in scope of delivery

## Dimension Table

Flange Design	DN50 PN6	DN50 PN16	DN50 PN16	DN80 PN16	DN80 PN16
A	Ø 140 [5.51"]	Ø 165 [6.50"]	Ø 165 [6.50"]	Ø 200 [7.87"]	Ø 200 [7.87"]
B	Ø 110 [4.33"]	Ø 125 [4.92"]	Ø 125 [4.92"]	Ø 160 [6.30"]	Ø 160 [6.30"]
C	70°	70°	70°	34.5°	34.5°
D	4 x 50°	4 x 50°	4 x 50°	8 x 24°	8 x 24°
E	Ø 13 [0.51"]	Ø 18 [0.71"]	Ø 18 [0.71"]	Ø 18 [0.71"]	Ø 18 [0.71"]
F	Ø 81 [3.19"]	-	Ø 81 [3.19"]	-	Ø 116.2 [4.57"]
G	Ø 65 [2.56"]	-	Ø 65 [2.56"]	-	Ø 65 [2.56"]
H	3 [0.12"]	-	3 [0.12"]	-	3.9 [0.15"]
I	12 [0.47"]	18 [0.71"]	18 [0.71"]	18 [0.71"]	18 [0.71"]
O-ring seal di x da x t	O-Ring 67mm x 79mm x 4mm 2.64" x 3.11" x 0.16"	for any seal (no seal in scope of delivery)	O-Ring 67mm x 79mm x 4mm 2.64" x 3.11" x 0.16"	for any seal (no seal in scope of delivery)	O-Ring ID100 x O 6 3.9" x 0.24"

# Flange Seals

O-ring for DN50/PN6/16

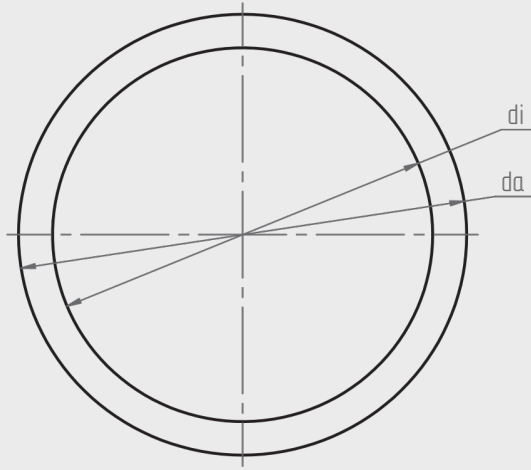

O-ring for DN80/PN16

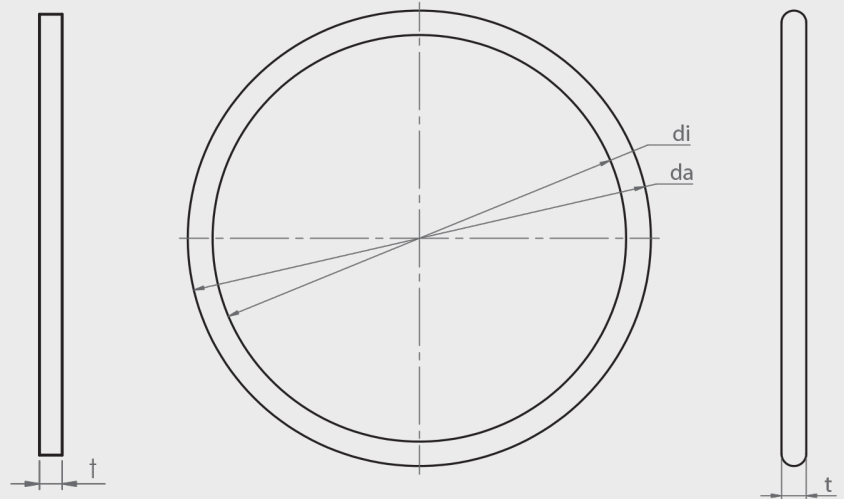

<b>TECHNICAL DATA</b>	Supply voltage	24 V DC
	Power consumption	15 W
	Mounting	On DIN rail
	Ambient conditions during operation	Ambient temperature for horizontal installation position: $-25...+70\text{ }^{\circ}\text{C}$ Relative operating humidity: 10...95 % non-condensing Air pressure and altitude: up to 2,000 m above sea level
	Contamination level	2
	Protection Class	II
	Degree of protection	IP 20
	Mounting Orientation	Horizontal
	Ambient conditions for transport storage	Temperature: $-40...+85\text{ }^{\circ}\text{C}$ Relative humidity: 10 % to 95 % non-condensing Air pressure: corresponds to 4,500 m above sea level
	Dimensions and weight	Please refer the diagram for Dimensions Weight: approx. 0.8 kg
<b>CHARACTERISTIC DATA</b>	Communication	Ethernet with 3 Ports, 2 separate networks: 2 x RJ45 (for protocol converter parameterization) 1 x RJ45 (for SCADA)
	Protocols	DNP 3.0 via Ethernet; Modbus TCP; IEC 61850-8-1 MMS (optional)
<b>OPTIONS</b>	Wide range power supply unit	Input 100...240 V AC 50/60 Hz ( $\pm 10\%$ ) 110...300 V DC ( $-20...+25\%$ ) Output 24 V DC / 80 W Temperature range $-25...+70\text{ }^{\circ}\text{C}$ Degree of protection IP 20 Dimensions W x H x D 32 x 124 x 102 mm

# PROTOCOL CONVERTER DIMENSIONS

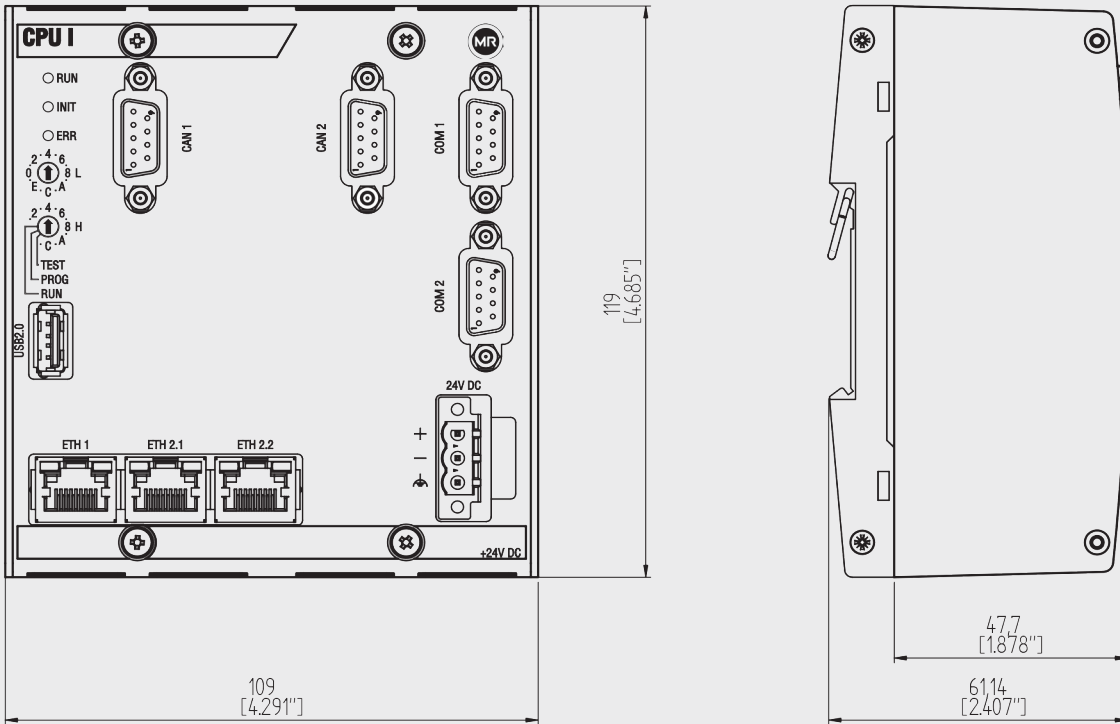

# WIDE RANGE POWER SUPPLY UNIT (OPTIONAL) DIMENSIONS

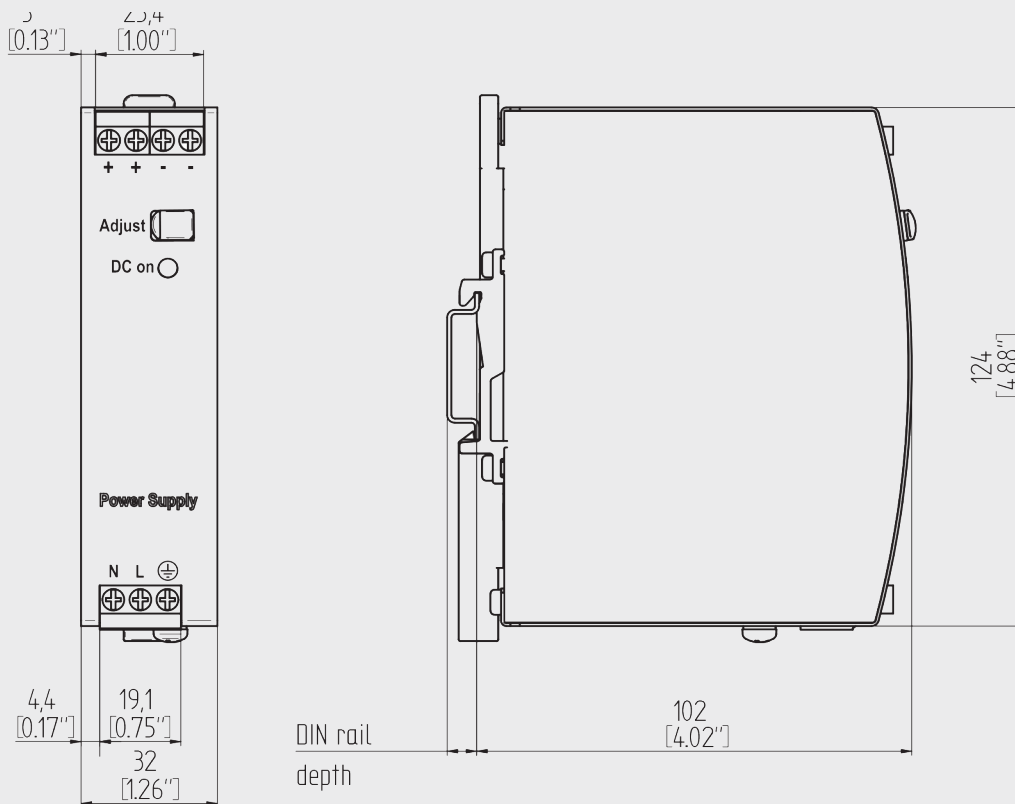

# Why Customers Choose Us?

RM solution, the trusted monitoring solution for over 10000+ assets across 50+ countries. We are a leading High Value Electrical Asset Monitoring Company integrating fibre optic technology to the assets.



## Attention to Details

It's our attention to the small stuff, scheduling of timelines and keen project management that makes us stand out from the rest.



## A plan for Success

Our Customers are well satisfied with the advisory services that we offer to help them with best in class technological performance and a long durable life.



## Experts only

We bring-in our diversified experienced team with over 100+ years of experience in Asset Monitoring



## Meeting Deadlines

Work with us, and you'll work with seasoned professionals – vigilant of deadlines, and committed to exceeding client expectations.



## Money Matters

We protect you against currency fluctuation with competitive and fair market prices





# Our Presence Across the Globe



## Head Office

 **Canada**

1415 Frank-Carrel, Suite  
230, Quebec, QC - G1N  
4N7, CANADA

 +1-418-767-0111

Asia Pasific | India | Europe | Latin America | Middle East | North America

## Rugged Monitoring Services

Rugged Monitoring provides customization of sensors, monitors & software. In addition we offer on-site commissioning services, maintenance contracts and technical support to all customers worldwide.

## About Rugged Monitoring

Industry's leading team of asset condition monitoring experts with 100+ years of combined experience committed to delivering customizable solutions for challenging applications. We offer a range of reliable, high performance, customizable sensors and monitoring solutions that are immune to external influence.



 ruggedmon

 [info@ruggedmonitoring.com](mailto:info@ruggedmonitoring.com)

 [www.ruggedmonitoring.com](http://www.ruggedmonitoring.com)

©2021 Rugged Monitoring Company. All rights reserved. Information subject to change without notice. All trademarks are properties of their respective companies, as noted herein.