

# Air Insulated Switchgear Monitoring Solution

Designed for Diverse Utility and Industry Applications

## Achieve increased asset value with improved productivity and utilization

Electrical switchgear plays an important role in operating the electrical power system safely with high reliability. Malfunction in switchgear operations can lead to severe failures in transformers and other connected electrical assets. The switchgear failures may lead to damage of electrical assets, unplanned outages, as well as cost and resources. Monitoring and tracking their performance are important for an efficient and increased asset lifetime.

Rugged Monitoring offers an advanced comprehensive condition monitoring solution for various switchgear systems from; sensors, monitors to software which can monitor and analyze the performance of switchgear equipment. Depending on specific operating requirements and application, we customize our condition monitoring solutions for air insulated switchgear.

Our condition monitoring system can be installed and integrated in new installations as well as in existing switchgears. Our advanced condition monitoring solution provides operators with valuable insights about switchgear systems enabling them to increase asset effectiveness.



### Temperature Monitoring

The increasing demand for electric power and growing renewable energy sources call for the need to protect power systems from huge failures that could lead to a prolonged shortage of power supply. To ensure a continuous supply of power, condition monitoring of Switchgears becomes utmost important.

Overheating caused by uneven loads on circuits, or loose or damaged connections will lead to catastrophic failure's and thereby reduce the life span of the equipment. Temperature rises in switchgear and switchboard components can occur suddenly, often causing thermal run-away, resulting in burning, melting and destruction of components. Periodic visual inspections are always expensive and require special safety considerations and are unlikely to detect these conditions in time.

Rugged Monitoring offers an advanced comprehensive condition monitoring solution for various switchgear systems from; sensors, monitors to software which can monitor and analyze the performance of switchgear equipment. Depending on specific operating requirements and application, we customize our condition monitoring solutions for air insulated switchgear.

### What Can Be Monitored



**Temperature**



**Power**



**Partial Discharge**



**Humidity**



**Trip Close  
Characteristics**



**SF6  
Analysis**



**Stored Energy  
Analysis**



**Contact  
Wear**

## Partial Discharge Monitoring

We at Rugged Monitoring offer an advanced comprehensive condition monitoring solution for various switchgear system from; sensor, monitor to software which can monitor and analyze the performance of switchgear equipment. Depending on specific operating requirements and application, we customize our condition monitoring solutions for.

The major concern is to extract useful diagnostic data from noisy measurements (this holds especially for PD) and get global health condition/residual life algorithms. For noise recognition, while techniques are available for filtering out noise under AC sinusoidal voltage, that are based on the capability to distinguish noise from PD pulses in measurement records and, particularly, resorting to phase-resolved PD (PRPD) patterns, the same does not apply for DC and pulse-modulated (PWM) voltage waveforms.

## Sample System Architecture for Air Insulated Switchgear

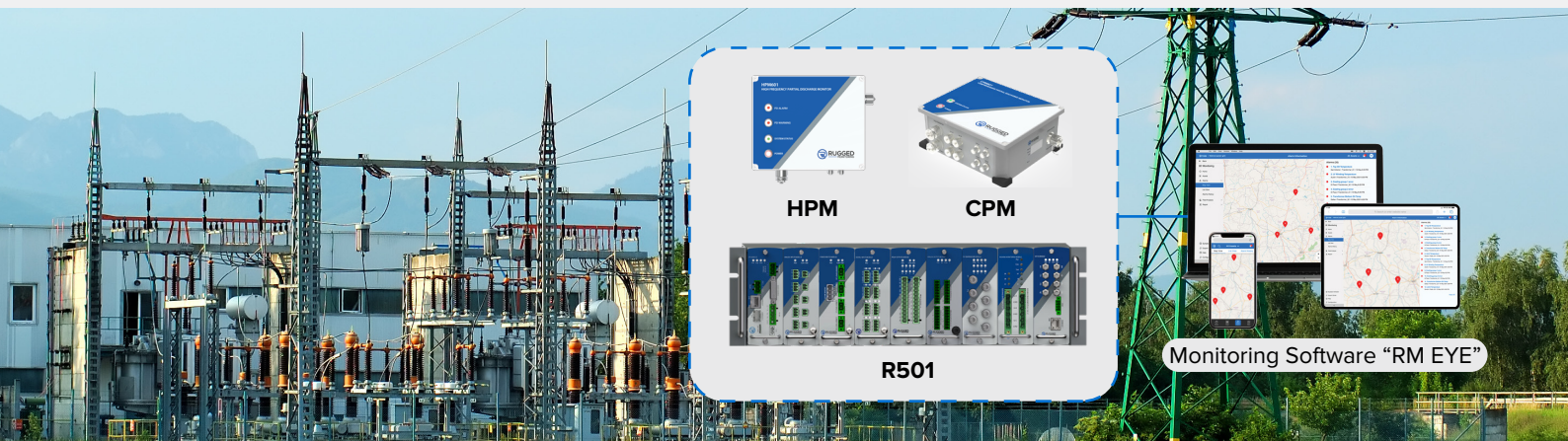

### Partial Discharge Monitoring

- PD Detection
- PD Localization
- PD Severity Analysis
- PD Test and Measurement Services

### Intrusion Detection

- Video camera
- Integrated with thermal imaging camera
- Real-time monitoring and Alarm Notification

### Thermal Monitoring

- Thermal Profiling
- Hot Spot Identification
- Hot Spot Localization

## Features

- Most advanced remote monitoring solution with contact wear analysis
- Trip & Close Operations Time Monitoring and Analysis
- SF6 Monitoring & Analysis with versatile and scalable operation
- Get Switchgear & Bay Level Information with Quick and flexible configuration options
- Realtime and consistent monitoring solution
- Built on well-established remote and cloud-based monitoring technology
- Robust and highly reliable

## Benefits

- Increased asset life with reduced unplanned outages
- Accurate alarm and alert system
- Greater diagnostic capability
- Increased ROI with reduced operation cost
- Precise fault identification
- Ability to monitor multiple switchgear systems with one software

# T301 Rugged Monitoring Temperature Monitor



The Rugged Monitoring T301 is a multi-channel fiber optic temperature monitor with precision measurement for Industrial and Laboratory applications. The T301 fiber optic monitor combines compact form factor and user-friendly interface in the monitor and software.

It is designed to operate reliably in extreme EMI, RFI, Microwave and high voltage environments. The T301 has a measuring range from  $-271^{\circ}\text{C}$  to  $+300^{\circ}\text{C}$ . The system offers complete immunity to RFI, EMI, Chemical, microwave radiation, and high voltages making it an optimal choice for environments where the limitations of conventional temperature sensors / monitors impact usage in extreme conditions. The system is based on proven zero-drift GaAs technology and designed for Plug and Play operation.

The T301 is designed to collect data and to easily integrate into existing systems through serial communication like RS-485 or Gigabit Optical Ethernet. The T301 monitor comes with Rugged Connect software which is designed with the needs of Test Platform or Industrial Process monitoring integration needs. It has the data integration capability of multiple test platforms. Rugged Connect software is designed to collect data from 256 channels simultaneously. Plug and Play functionality provides the flexibility to interchange sensors without the inconvenience / concerns of calibration.

Rugged Monitoring has a dedicated team for application specific customizations for fiber optic sensors, monitor configuration and software integration to simplify the data collection of testing and monitoring applications.

## Applications

- Transformer Hot Spot monitoring
- Industrial process control and monitoring
- Electric Vehicle and Battery Testing
- Medical Equipment testing (MRI, PETSCAN, NMR)
- Commercial Grade Microwave Radiation
- Food and Beverage Processes

## Features

- Rugged, Compact Design
- 4 to 24 Channels, Expandable
- Plug and Play, No field calibration
- Best in class EMI, ESD Immunity
- 8 Programmable relays, Form - C
- Software designed to be interfaced with other testing platforms

## Benefits

- No shift over time, high stability
- Robust packaging
- Each Monitor comes with a complete NIST calibration Certificate
- Software designed for integration into test platforms
- Robust datalogging and analytics
- Customizable according to customer specific applications
- Suitable for OEM-type applications.

## Ordering Code

**Number of Channels**

Ex: 08 = 8 Channels

T 3 0 1 - [ ] [ ]

**Number of Analog Outputs**

0 = No Analog Outputs

8 = 8 Analog Outputs

[ ] [ ] E A R M

**Memory Size**

0 = None

4 = 4 GB

8 = 8 GB

**Ethernet Protocols**

0 = No Ethernet

1 = Ethernet (1x RJ45, 1x SFP port auto)

2 = Ethernet (1x RJ45, 1x SFP module 1Gbps)

3 = Ethernet (1x SFP port 1Gbps, 1x SFP port auto)

4 = Ethernet (2x SFP modules 1Gbps)

5 = Ethernet (1x RJ45, 1x SFP module 100 Mbps)

6 = Ethernet (1x SFP port 100 Mbps, 1x SFP port auto)

7 = Ethernet (2x SFP modules 100 Mbps)

**Number of Relays**

0 = No Relays

8 = 8 Relays

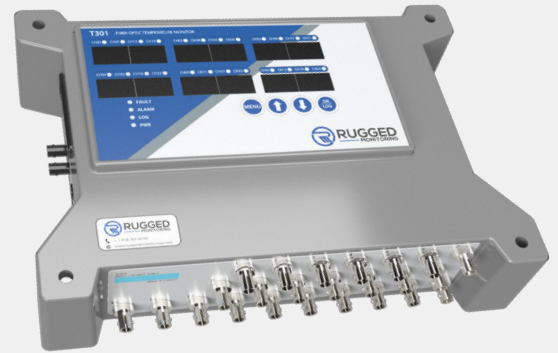

## Technical Specifications

Measurement Range	-80 °C to +300 °C (cryogenic 4 °K range optional)
Measurement range (Optional Range extensions)	Down to 2 °K / Up to +300 °C
Power Supply	24V to 48V DC, 30 W
Resolution	0.1 °C
Accuracy	±1.0 °C (±0.2 °C in relative temperature)
Scan rate	200 ms / channel
Memory	MicroSD external memory slot (Up to 2 TB)
Logging	10 years at 10 sec interval rate (8 GB)
Serial Port	RS-485 with Modbus
Ethernet Option	RJ-45 or Fiber Ethernet; Optional PRP support built-in 2 x RJ-45 or Fiber Ethernet; With advance communication protocols (IEC 61850, Modbus over Ethernet, IEC 60870-5-104 and DP3)
Fiber Optic Communication	SFP module can be added to the Ethernet option; the standard SFP module is compatible with LC fiber connectors (850 nm multimode communication with a distance capability of 550 meters)
Analog Outputs	8 fully configurable 0-10 V / 4-20 mA optional module available - Optional
Max # of Channels	256 Channels, Daisy chain up to 32 units (with Modbus)
Relays	8 Programmable Form-C Relays (5A) plus 1 system fault relay - Optional
Operating temp	-40 to 72 °C
Storage temp	-40 to 85 °C
Number of Channels	4 - 24 channels
Dimensions	10.5" x 7.4" x 2.8" 26.7W x 18.7D x 7.2H cm
Humidity	95% Non Condensing

# O201 Fiber Optic Temperature Monitoring with most advanced

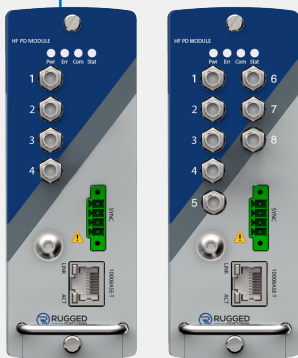

**RM's Fluorescence technology based O201 is designed with high accuracy, reliable for operation in extreme EMI, RFI, Microwave and high voltage environments. It is a multi-channel fiber optic temperature monitor with precision measurement for Original Equipment manufacturers. The O201 has a measuring range from -271 °C to +300 °C. The system is based on proven Fluorescence technology and designed for Plug and Play operation.**

The system offers complete immunity to RFI, EMI, microwave radiation, and High Voltages making it an optimal choice for environments where the limitations of conventional temperature sensors/ monitors impact usage in extreme conditions.

The O201 is designed to collect data and is easy to integrate into existing systems through serial communication like RS-485 or analog outputs like 0-10 V / 4-20 mA. The O201 supports Modbus, CANbus protocols and a system fault relay. The module is designed with capability to add additional application logic for customer specific applications. It is designed with the needs of Monitoring, Test platforms or Industrial Process monitoring integration needs. It has the data integration capability of multiple test platforms. Industry standard drivers available for a quick and easy connect to most popular laboratories software. The fluorescence based fiber optic temperature sensor is highly capable of operating in a series of complex environments such as strong electromagnetic and high voltage.

Rugged Monitoring designs and manufactures customized state of the art fiber optic sensor systems for the measurement of temperature, strain and other physical parameters.

**Our fiber optic temperature monitor with Fluorescence technology suits the requirement of measurements with difficult environmental conditions.**

## Features

- Rugged, Compact Design
- 1 to 8 Channels, Expandable
- Plug and Play
- Best in class EMI, ESD Immunity
- Software designed to be interfaced with other testing platforms

## Applications

- Electric Vehicle and Battery Testing
- Medical Equipment testing (MRI, PETSCAN, NMR)
- Commercial Grade Microwave Radiation
- Industrial process control and monitoring applications
- Chemical and process Industries Food and Beverage Processes
- Wood drying industry

## Benefits

- Robust and Reliable
- Offers a low-cost interrogator
- Suitable for OEM-type applications
- Sensors do not require any recalibration
- No shift over time, high stability and repeatability
- Robust packaging
- Each Monitor comes with a complete NIST calibration certificate
- Software designed for integration into test platforms
- Robust datalogging and Analytics
- Customizable according to customer specific applications
- Suitable for OEM-type applications.

## Ordering Code

**O201 = Original Equipment Module, 201 Series**

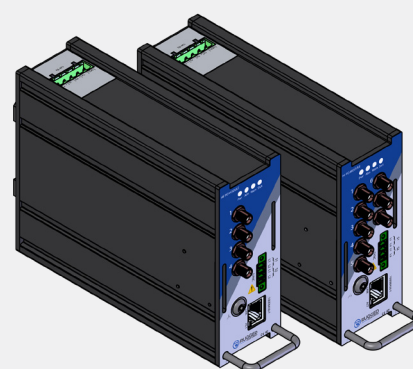
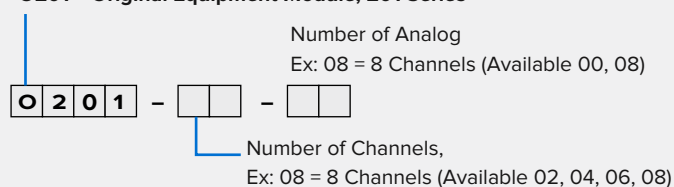

## Technical Specifications

Measurement Range	-80 °C to +300 °C (cryogenic 4 °K range optional)
Measurement range (Optional Range extensions)	Down to 4 °K / Up to +300 °C
Resolution	0.1°C
Accuracy	±1.0 °C (+/- 0.2 °C in relative temperature)
Number of Channels	1 - 8 Channels
Logging	1 sec interval on USB / Micro SD card
Config port	USB (to use with Rugged connect windows software)
Max # of Channels	Expandable to 256 Channels, Daisy chain up to 32 units (with Modbus, Canbus)
Communication Ports	RS-485 (RS-232 optional converter) with Modbus, CANbus
Power	24 VDC
Memory	MicroSD external memory slot (up to 2 TB)
Analog output module	Fully configurable eight 0-10 V / 4-20 mA module (Optional)
Dimensions	4.72" x 6.34" x 1.89" 120 x 161 x 48 mm
Scan rate	200 ms / channel (Optional: Faster scanning rates available)
Operating temp	-40 to 72 °C
Storage temp	-40 to 85 °C
Humidity	95% Non-Condensing
Relay	System Fault relay (5A)

# LSENS-R Fiber Optic Temperature Sensor

**Recommended for hostile environment where it is exposed to high vibration and immunity to electric fields is mandatory**

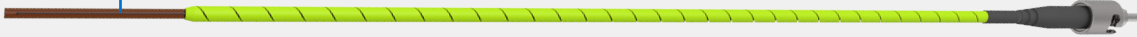

A multiuse fiber optic temperature sensor designed for a wide range of applications, especially for the use in demanding applications. The sensor offers complete immunity to RFI, EMI, NMR and microwave radiation. The standard temperature sensor has a response time of 0.2 s. With a standard deviation of  $\pm 0.2$  °C it allows for precise and repeatable measurements.

The coating of the temperature sensor is made of PTFE, and the fiber tip has a diameter of 1.7 mm with Rugged Polyimide coating and has a stainless steel ST-connector. For mechanical stability and applications e.g. in oil special protective coatings and hoses are available. The fiber optic probe consists of a PTFE protected glass fiber and a GaAs-crystal (Gallium Arsenide) at the sensor tip. It is totally free of metal and immune to external fields, therefore probes are explicitly suitable for the use in high temperature ranges as well as in aggressive operating environments. The sensor cable can be from several meters to kilometers long without influencing the accuracy of the measurement result. Other sensor lengths and connector types are available upon request.

## Applications

- Industrial process control and monitoring applications
- High voltage environments
- Harsh and Hazardous environments
- Temperature measurements conducted in confined spaces, hazardous or strong EMI/RFI/MRI environments
- Wood drying industry

## Features

- Industrial use with rigid polyimide tip, 1.7 mm diameter
- Rugged tip ideal for industrial application
- Complete immunity to EMI/RFI/lightning
- High vibration environments

## Benefits

- Sensors do not require any recalibration
- No shift over time, high stability
- Robust packaging
- Each sensor comes with a complete test certification
- Robust fiber optic temperature sensor
- Available in different cables and sheath options
- Customizable according to customer specific applications
- Suitable for OEM-type applications.



## Technical Specifications

Temperature range	-200 °C to +250 °C
Temperature range (Optional Range extensions)	Down to 4 °K / Up to +300 °C
Repeatability	0.2 °C
Accuracy absolute temperature	+/- 0.8 °C
Accuracy relative temperature	+/- 0.2 °C
Probe sheathing material	Teflon Coated, Rugged Polyimide protection for sensor tip
Connector	Stainless Alloy / Optional - Dielectric
Response time	Up to 0.2 Sec
Probe sensitive area - Diameter	1.7 mm Diameter
Longevity	Probe accuracy & repeatability constant over time

## Ordering Code

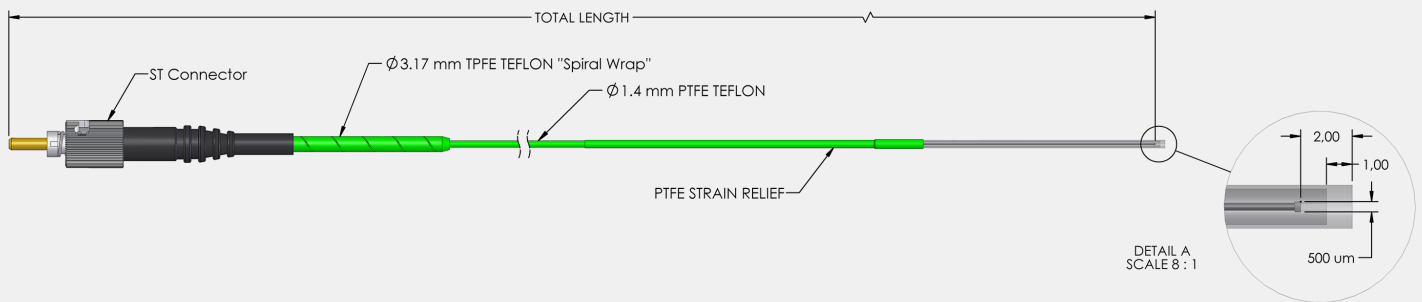
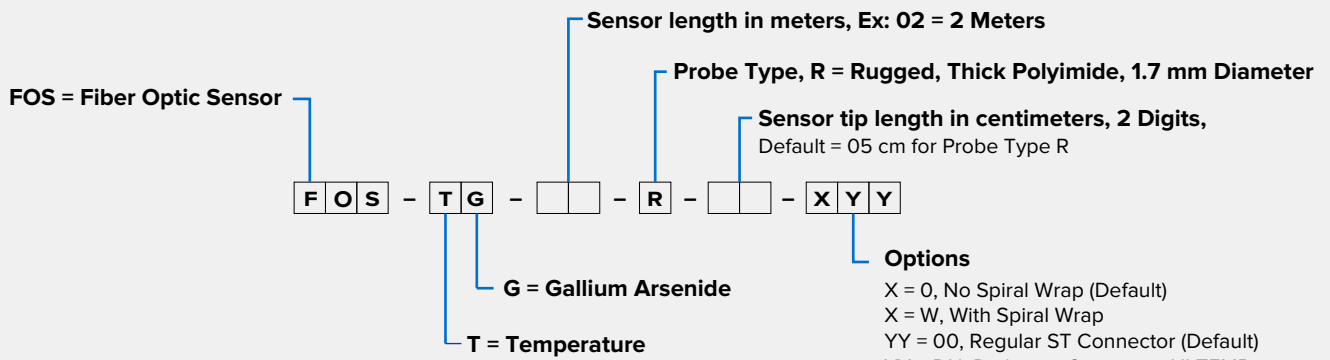

# LSENS-T Fiber Optic Temperature Sensor

**A multiuse fiber optic temperature sensor for measurement in a wide range of demanding applications where immunity to electromagnetic fields and explosion proof requirements are mandatory**

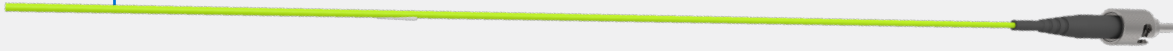

A multiuse fiber optic temperature sensor designed for a wide range of applications, especially for the use in R&D and industrial applications. The sensor offers complete immunity to RFI, EMI, NMR, Corrosive and microwave radiation making it the best choice for all demanding applications. The standard temperature sensor has a response time of 0.2s. With a standard deviation of  $\pm 0.2$  °C it allows precise and repeatable measurements. The coating of the temperature sensor is made of PTFE, while the fiber tip has a diameter of 1.1mm and has a stainless steel ST-connector. For mechanical stability and applications e.g. in oil special protective coatings and hoses are available. The fiber optic probe consists of a PTFE protected glass fiber and a GaAs-crystal (Gallium Arsenide) at the sensor tip. It is totally free of metal and immune to external fields, therefore probes are explicitly suitable for use in high temperature ranges as well as in aggressive operating environments. The sensor cable can be from several meters to kilometers long without influencing the accuracy of the measurement result. Other sensor lengths and connector types are available upon request.

## Applications

- Magnetic, RF and Microwave environments  
High voltage environments
- Nuclear and hazardous environments
- Medical applications
- Aggressive Chemical environments  
Sterilization applications
- RF and microwave drying applications

## Features

- PTFE protected  
Outstanding repeatability with high flexibility
- Complete immunity to RFI, EMI, NMR and  
microwave radiation
- Does not require recalibration or complex  
input to operate  
Liquid proof and withstands aggressive  
chemical solutions

## Benefits

- Sensors do not require any recalibration
- No shift over time, high stability
- Optional spiral wrap
- Robust fiber optic temperature sensor
- Available in different cables and sheath options
- Customizable according to customer specific applications
- Suitable for OEM-type applications

## Technical Specifications

Temperature range	-200 °C to +250 °C
Temperature range (Optional Range extensions)	Down to 4 °K / Up to +300 °C
Repeatability	0.2 °C
Accuracy absolute temperature	+/- 0.8 °C
Accuracy relative temperature	+/- 0.2 °C
Probe sheathing material	Teflon Coated
Connector	Stainless Alloy / Optional - Dielectric
Response time	Up to 0.2 Sec
Probe sensitive area - Diameter	1.4 mm

## Ordering Code

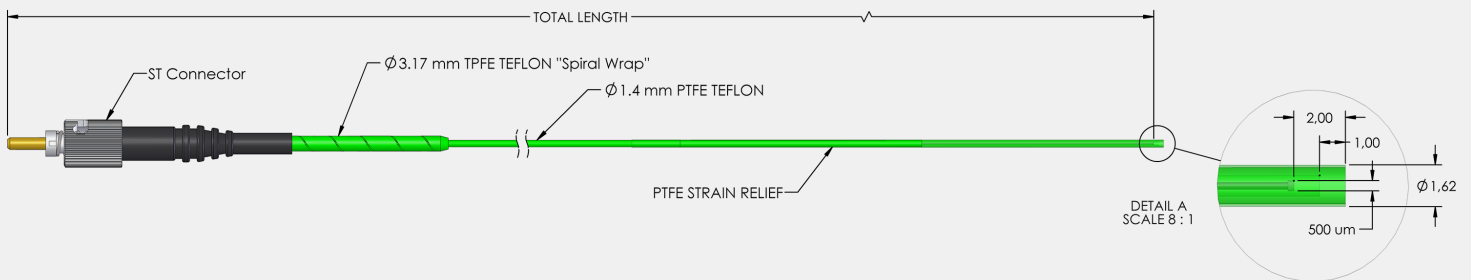
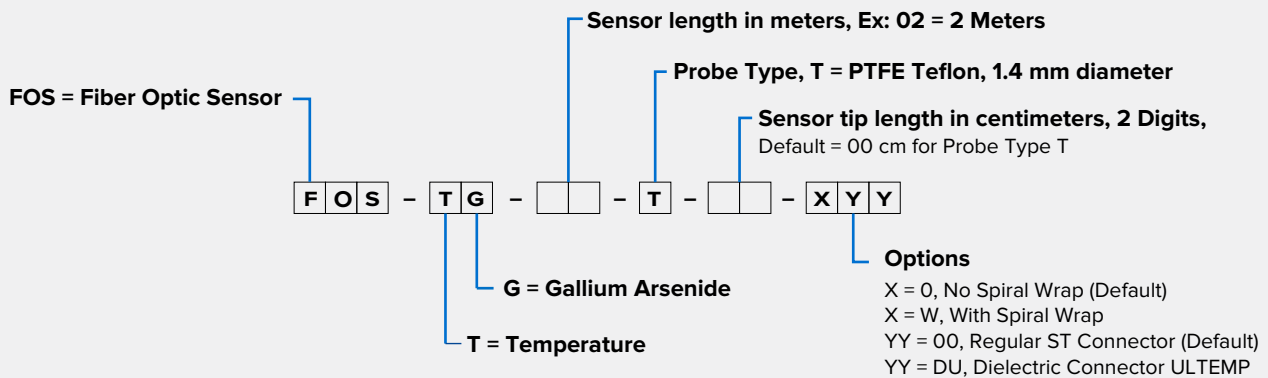

# LSENS-U Fiber Optic Temperature Sensor

**A Heavy duty fiber optic temperature sensor for measurement in a wide range of demanding applications where robustness of sensors, immunity to electromagnetic fields and explosion proof requirements are mandatory**

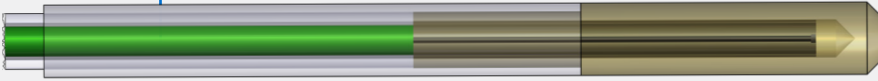

A heavy duty fiber optic temperature sensor specially designed for harsh and dynamic operating conditions where stress on the Fiber Optic Cable is more than normal. The sensor offers complete immunity to RFI, EMI, NMR, Corrosive and microwave radiation making it the best choice for all demanding applications. The standard temperature sensor has a response time of 0.2 s. with a standard deviation of  $\pm 0.2$  °C. Each sensor allows precise and repeatable measurements.

The coating of the temperature sensor is made of heavy duty material, while the fiber tip has a diameter of 1.1mm and has a stainless steel ST-connector. For mechanical stability and applications e.g. in oil special protective coatings and hoses are available.

The fiber optic probe consists of a PTFE protected glass fiber and a GaAs-crystal (Gallium Arsenide) at the sensor tip. It is totally free of metal and immune to external fields, therefore probes are explicitly suitable for use in high temperature ranges as well as in aggressive operating environments. The sensor cable can be from several meters to kilometers long without influencing the accuracy of the measurement result. Other sensor lengths and connector types are available upon request.

## Features

- Heavy duty protection gives longevity to sensors under harsh and dynamic operating conditions
- Complete immunity to RFI, EMI, NMR and microwave radiation
- Outstanding repeatability improves accuracy of testing instruments
- Plug and Play operation, does not require recalibration or complex input to operate
- Liquid proof and withstands aggressive chemical solutions

## Applications

- RF and microwave drying applications
- Food Processing and sterilization applications
- Electric Vehicle and Battery Testing
- Medical Applications
- Industrial process control and monitoring applications
- Nuclear, Magnetic and hazardous environments
- High voltage environments
- Aggressive Chemical environments

## Benefits

- Longer life of sensors under harsh and dynamic operating conditions
- Cost saving on recalibration; sensor does not require any recalibration
- Customizable to meet different requirements of customer applications
- Optional spiral wrap reinforces robustness of sensor cable
- Suitable for OEM-type applications and during operation of machines
- Higher accuracy and repeatability increase confidence of validation and measurement
- Faster support from industry known fiber optic experts
- Available in different cables and sheath options

## Technical Specifications

Temperature range	-200 °C to +250 °C
Temperature range (Optional Range extensions)	Down to 4 °K / Up to +300 °C
Repeatability	0.2 °C
Accuracy absolute temperature	+/- 0.8 °C
Accuracy relative temperature	+/- 0.2 °C
Probe sheathing material	Teflon Coated
Connector	Stainless Alloy / Optional - Dielectric
Response time	Up to 0.2 Sec
Probe sensitive area - Diameter	1.6 mm

## Ordering Code

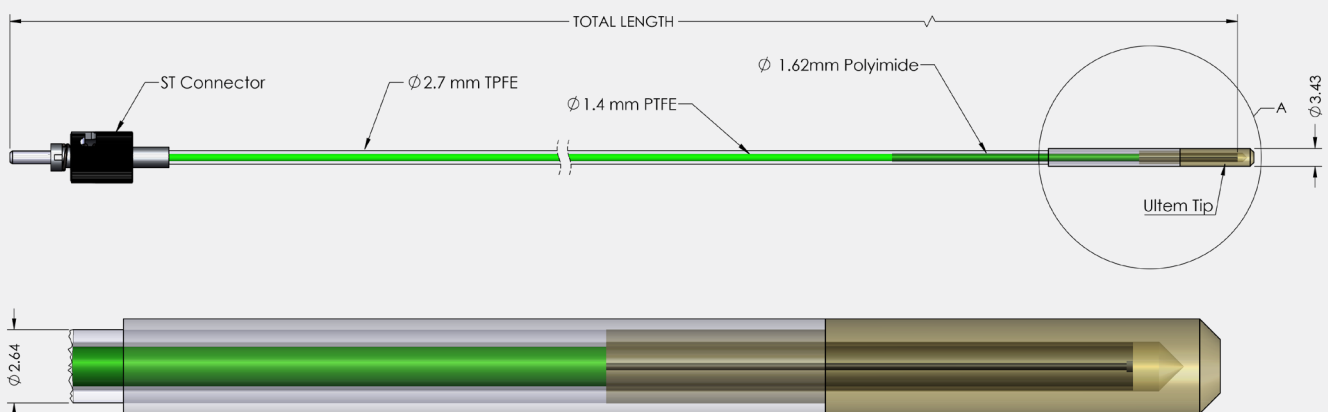
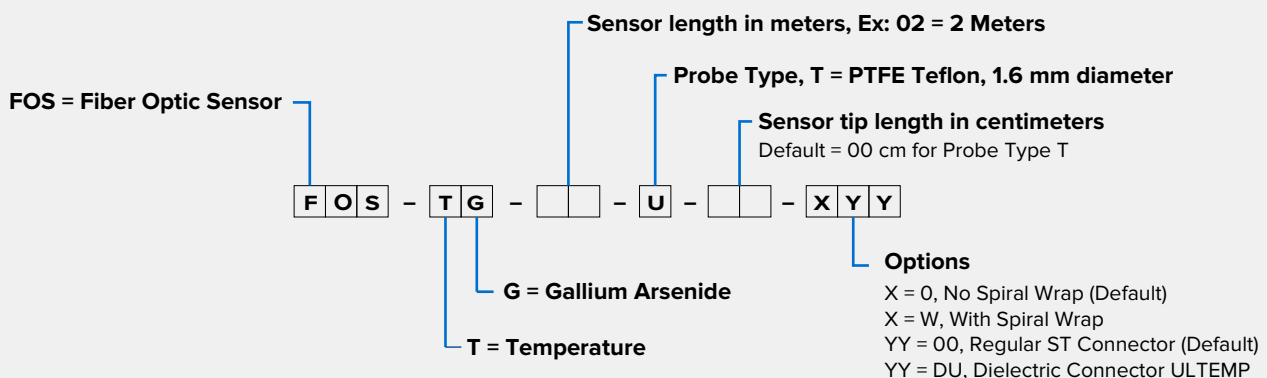

# Asset Monitoring : Enterprise Architecture

Compatible with Rugged Monitoring Enterprise Solution

## UI UX

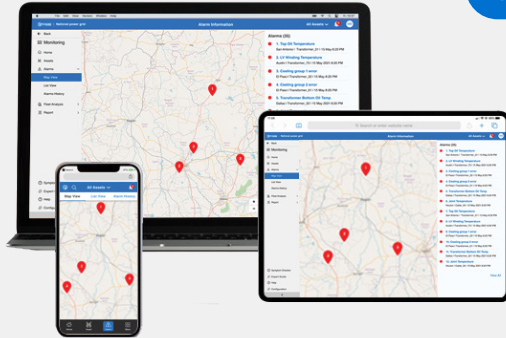

- Data Layer
- Analytics
- User Interface
- Custom Dashboards
- Reporting
- Email/SMS Notifications

## RM EYE

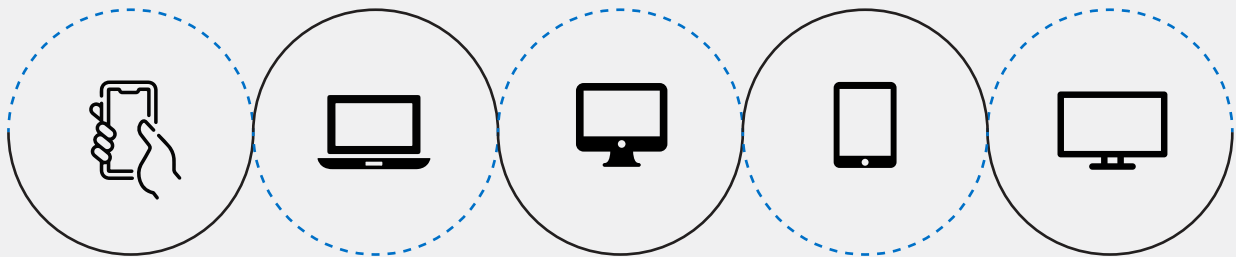

Private Cloud (Customer Cloud),  
Rugged Monitoring Cloud

**IEC 60870-104**

**IEC 61850**

**FTP/SFTP**

- XML, JSON
- CSV, COMTRADE



**Data Collection**

**ODBC**

**MODBUS**

**DNP 3.0**

**HTTPS**

**MQTT**

## Asset Data

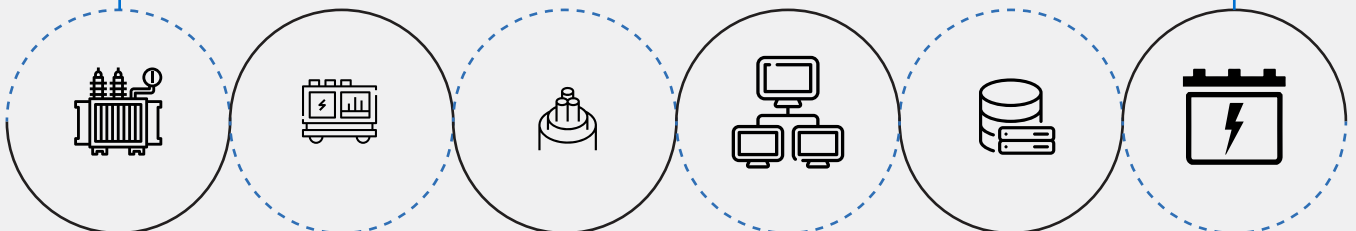

Transformer  
Monitoring  
System

Switchgear  
Monitoring  
System

Power Cable  
Monitoring - Inspection Records  
System - Name Plate

- Historian  
- CMMS  
- SCADA/ DCS

Power Electronics  
(Battery, UPS,  
VFD, Relay)

# One Solution for Multi-Site Multi Asset Monitoring

**RM Eye - Unified platform to monitor entire network  
of electrical assets**

## Features

- **Advanced asset health monitoring** with analysis and recommendations to increase asset effectiveness in addition to maximizing equipment uptime
- **Modern remote monitoring solutions** provide valuable insights to Multiple Assets at Multiple Sites from time to time
- **Establish a real time and consistent monitoring** by getting the right information into right hands
- **Simple and user-friendly interface** providing easy and fast access to all the features
- **Everything about the asset at one place**  
The raw data, analysis and recommendations
- **Advanced asset algorithms** for electrical assets to evaluate asset health
- **Advanced reporting technology with automated alerts**
- **An efficient, reliable partial discharge monitoring for all the assets**
- **A detailed comprehensive DGA analysis**
- **Built on well-established remote and cloud-based monitoring technology**
- **Quick configuration** so that you are not required to configure separately.
- **Protocols: IEC 61850, MODBUS, MQTT**
- **Robust integration with 3rd party systems and devices** with industry standard protocols
- **Bulk configuration imports for fast deployment**
- **Encompasses a secure access to data and configuration**
- **QR code scanner on mobile devices**
- **Accessible on web browser and mobile app**
- **Historical data storage and on demand access** via export feature
- **Extended multilingual support** to handle product inquires or troubleshoot problems proactively
- **Systematic fleet management analysis**
- **Offline test data integration and analysis**

# Why Customers Choose Us?

RM solution, the trusted monitoring solution for over 10000+ assets across 50+ countries. We are a leading High Value Electrical Asset Monitoring Company integrating fibre optic technology to the assets.



## Attention to Details

It's our attention to the small stuff, scheduling of timelines and keen project management that makes us stand out from the rest.



## A plan for Success

Our Customers are well satisfied with the advisory services that we offer to help them with best in class technological performance and a long durable life.



## Experts only

We bring in our diversified experienced team with over 100+ years of experience in Asset Monitoring



## Meeting Deadlines

Work with us, and you'll work with seasoned professionals – vigilant of deadlines, and committed to exceeding client expectations.



## Money Matters

We protect you against currency fluctuation with competitive and fair market prices





## Rugged Monitoring Services

Rugged Monitoring provides customization of sensors, monitors & software. In addition we offer on-site commissioning services, maintenance contracts and technical support to all customers worldwide.

## About Rugged Monitoring

Industry's leading team of asset condition monitoring experts with 100+ years of combined experience committed to delivering customizable solutions for challenging applications. We offer a range of reliable, high performance, customizable sensors and monitoring solutions that are immune to external influence.

# Certification



ISO 9001



ISO 14001



ISO 45001/  
OHSAS 18000



Lloyd's  
Register



ATEX  
Certification

# Our Presence Across the Globe



## Head Office

 **Canada**

1415 Frank-Carrel, Suite  
230, Quebec, QC - G1N  
4N7, CANADA

 +1-418-767-0111

[Asia Pasific](#) | [India](#) | [Europe](#) | [Latin America](#) | [Middle East](#) | [North America](#)



 [ruggedmon](#)

 [info@ruggedmonitoring.com](mailto:info@ruggedmonitoring.com)

 [www.ruggedmonitoring.com](http://www.ruggedmonitoring.com)

©2024 Rugged Monitoring Company. All rights reserved. Information subject to change without notice. All trademarks are properties of their respective companies, as noted herein.

# T501

## Rugged Monitoring Temperature Monitor



Power transformers play a vital role in the electrical system and undergo critical stress most of the times. Rugged Monitoring T501 offers a whole range of functions designed to let the utilities use their transformers to the greatest limit by accurately monitoring all parameters required to calculate health index in order to maximize asset life.

Our advanced transformer monitoring system T501 is capable to perform but not limited to data logging, event recording, dynamic loading analysis, remote communication including IEC 61850. Keeping an eye on your transformer, the monitoring system can be integrated with various fiber optic sensors for direct winding temperature monitoring, H2Sens and any other third party online dissolved Gas Analyzer for measurement of gas in oil.

A monitoring system must be Robust, Reliable and Responsive, Our system meets all these features and is competent to perceive.

### Options

- Integrated data logging (up to 20 parameters) and Event recording (up to 8 events)
- Ethernet port and/or fiber optic communications output (RS485)
- Weather proof enclosure with or without heater, 19" rack mount or control cabinet panel mount
- Oil RTD, Ambient RTD, clamp on CT, pressure transducer, oil level transmitter along with various other input modules.

### Benefits

- Proactive Risk Monitoring
- Improved asset protection and utilization
- Simplified analysis for condition-based maintenance
- Intervention before failure and Malfunctioning
- Optimize loading and equipment life

### Features

- 8 relays (1 dedicated for system status) for alarm and control based on up to 8 modular inputs of various types.
- 4 magnetically isolated current loop outputs (0-1 or 4-20mA selectable)
- RS 485 remote communication, fiber optics (Rs-485) communications and Ethernet ports
- Transformer monitor for condition based, continuous online monitoring of asset health (CBM).
- Interfaces with a variety of Rugged
- Monitoring and third party smart sensors, as well as traditional gauges to accurately measure transformer parameters vital to asset management.
- Web based software is specifically designed for ease of unit commissioning, setup and daily use.

## Technical Specifications

<b>POWER SUPPLY</b>	Input Power Requirement	24/48 VDC $\pm$ 10%
	Power Consumption	20 Watts
<b>ANALOG/DIGITAL INPUT MODULE</b>	# of Input Channels	08/04 Channels
	Input Channel Types	Configurable from a range of input options, RTD, AC/DC current, AC/DC voltage, Potentiometer, Dry/Powered contact switch
	Accuracy of Channels	$\pm$ 0.5% full scale input range
	Input Channel Sample Rate	1 Hz
<b>FIBER OPTIC MODULES</b>	Measurement Range	-80°C to +300°C (cryogenic 4°K range optional)
	Resolution	0.1°C
	Accuracy	$\pm$ 1.0 °C ( $\pm$ 0.2°C in relative temperature)
	Scan Rate	200 ms / channel ( Optional: Faster scanning rates available)
	Number of Channels	2 to 24 channels
<b>ANALOG OUTPUT MODULE</b>	# of Output Channels	04 Channels
	Output format	4-20 mA or 0-5Vdc / 0-10Vdc (Configurable for any measured / calculated value)
<b>OUTPUT RELAY MODULE</b>	# of Output Channels	08 Form C relays (5A)
	User Programmable	Yes, from Rugged Connect Software or webserver, if present
<b>DATA STORAGE &amp; CONFIGURATION</b>	Data Storage Capacity	4 or 8 GB, Industrial Grade micro-SD, extendable to 2TB
	Logging Rate	User Configurable, 1 sec interval on USB
	System Fault Indication	1 System Fault Relay, with Local LED light
	Config port	USB (to use with Rugged connect windows software)
<b>COMMUNICATION</b>	Serial Communication	01 x RS-485 (RS-232 optional converter)
	Ethernet Communication	02 Ethernet Ports, configurable to RJ-45 or SFP (Gigabit Optical)
	Redundancy	Support PRP Redundancy
	Protocol Supported	Modbus, DNP3.0, IEC60870-104, IEC61850, Other protocols provided on request
<b>EMC TYPE TESTING</b>	Conducted & Radiated Emissions	ICES-003 (2016), CISPR32 (2015), CISPR11 (2015)
	ESD and EM Field Immunity	IEC61000-4-2, C37.90-3, IEC61000-4-3, C37.90.2
	Fast Transient & Surge Immunity	IEC61000-4-4, IEC61000-4-5, C37.90.2
	Magnetic Field Immunity	IEC61000-4-8, IEC61000-4-10
	Immunity from Conducted Disturbances	IEC61000-4-6, IEC61000-4-16
	Ripple, Dips & Damped Oscillatory	IEC61000-4-17, IEC61000-4-18, IEC61000-4-29
	Safety	IEC60255-26 and CE Certified
<b>ENVIRONMENTAL AND MECHANICAL</b>	Operating Temperature	-40 to 72°C
	Operating Humidity	95% Non Condensing
	Storage Temperature	-40 to 85°C
	Dimensions	W26.7 cm x H7.2 cm x D18.7 cm (10.5" x 2.8" x 7.4")
	Weight	App. 1.5 to 2.0 Kg. (based on number of configuration)

# R501 Rack Mount Comprehensive and Customizable Transformer Monitoring Solution



**Most Versatile, Multi Channel, Comprehensive Transformer Monitoring Solution**

**Single Monitoring Solution for: Temperature, Partial Discharge, Bushing, Load, Power, Losses and more...**

## Key Features

- Fully flexible rack mount and distributed architecture support
- Expandable to add different analog and (or) digital inputs and outputs
- Best in class EMI, ESD Immunity; range of communication options and protocol support
- Range of communication options for third party system integration
- Complies with the latest IEC/IEEE standards for Emission, Immunity, Safety and Environment.

## Benefit

- Improved reliability
- Accurate predictive analysis
- Access asset data from anywhere
- One monitoring solution for various parameters
- Increased lifetime
- Highest Return on Investment
- Field upgradable with no device downtime



## Sensors that can be connected to R501

1. OTI,WTI, RTD, PRD, Breather, Buchholz Relay, LLG/OLI, Pressure Sensor etc.
2. Direct winding Hot Spot Monitor
3. Cooling System and Control Cabinet
4. Dissolved Gas Analyzer
5. Bushing Monitoring
6. Partial Discharge Monitor

## Product Drawing

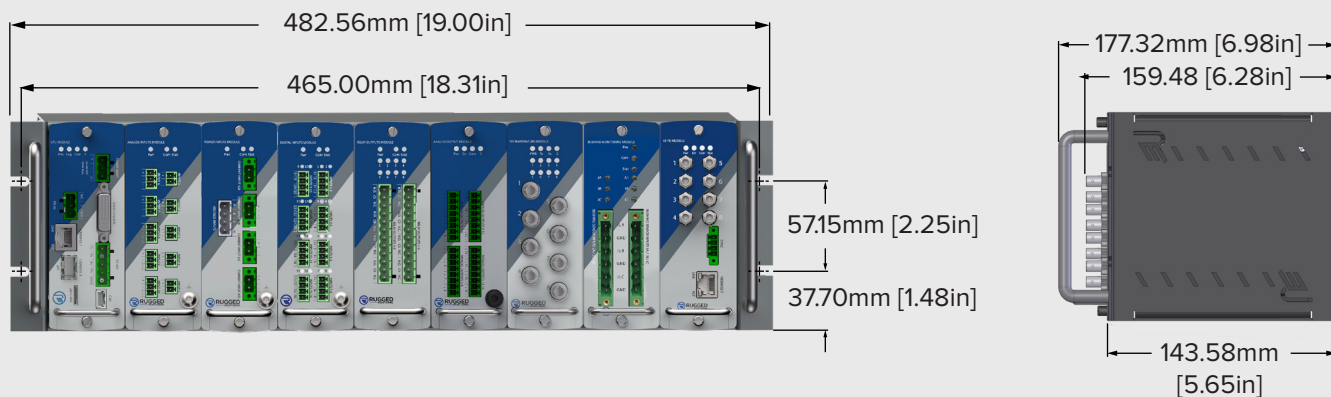

Weight : 5 Kilograms

### Optional Smaller 3U Chassis

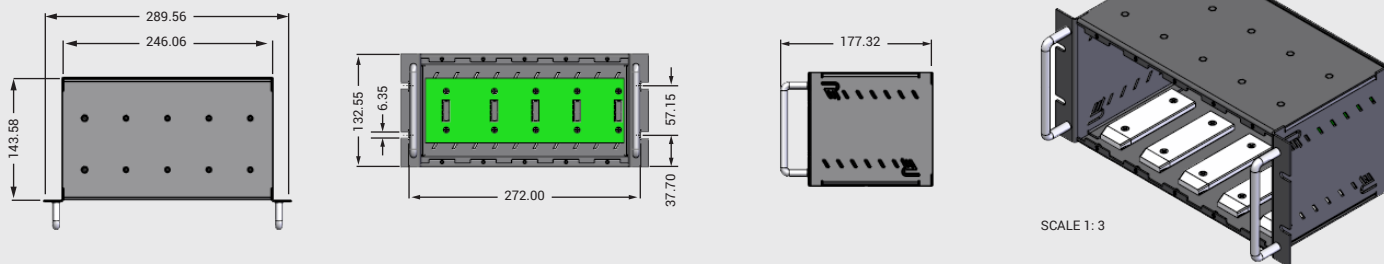

## Ordering Code

Contact our sales team for Ordering Code

## One Solution for Multi-Site Multi Asset Monitoring

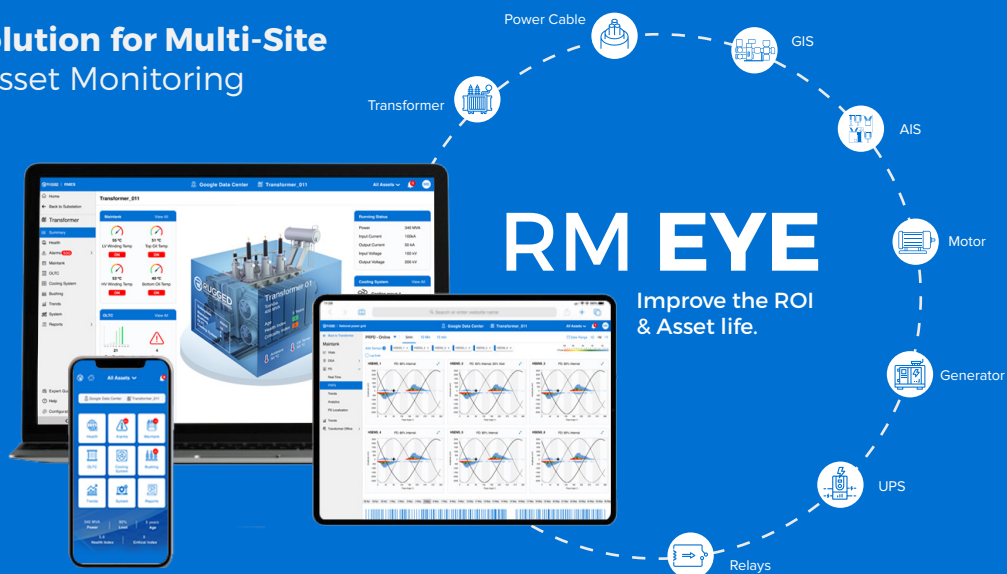

# R501 Monitoring Modules

Comprehensive Features to Meet Market Demand

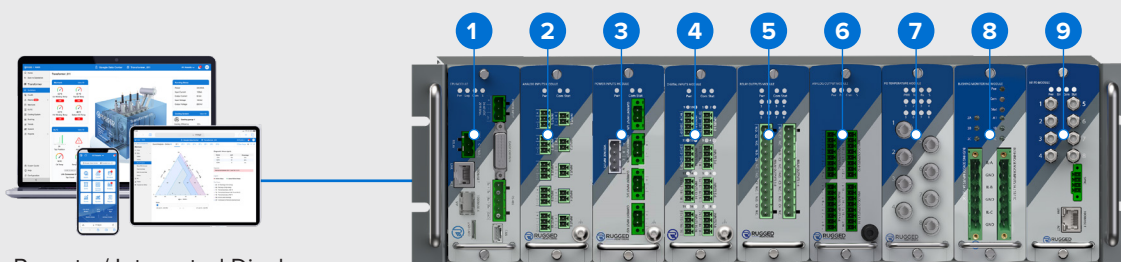

Remote / Integrated Display

## 1. CPU/GTW Module



### Option A. CPU Module

- Data Processing & Storage
- System Fault Relay
- 01 x Serial (RS485) ports
- 02 x Ethernet (PRP support)
- Health Assessment Analytics

### Option B. CPU with GTW

- Main rack with CPU, Slave rack with GTW
- Provides power to all modules
- Up to 4 Racks can be daisy chained
- 01 x Serial (RS485) ports

### Option C. GTW without CPU

- Main rack and slave racks with GTW
- Provides power to all modules
- Supports FOM and FLM modules
- Up to 4 Racks can be daisy chained
- 01 x Serial (RS485) ports

## 2. Analog Input Module



- 05 or 10 channels
- AC/DC current input
- RTD / Potentiometer
- Built-in LED indicators

## 3. Power Monitoring Module



- 03 Current & 03 Voltage Inputs
- Active, Reactive & Apparent Power
- Transformer Power Factor
- Through-Fault Monitoring (I2T)
- Current Signature Analysis
- OLTC Motor Torque

## 4. Digital Input Module



- 08 or 16 channels
- Input Voltage 75 - 250Vdc
- Threshold Voltage > 60V
- Built-in LED indicators

## 5. Relay Output Module



- 04 or 08 Form C Relays
- Dry contact (NO-C-NC)
- User Programmable
- Built-in LED indicators



## 6. Analog Output

- 08 or 16 Analog output
- DC Current Loop (4-20mA / 0-1mA)
- Dc Voltage (0-5V / 0-10V)
- User Programmable
- Built-in LED indicators



## 7. Fiber Optic Module

- 02, 04, 06 and 08 Channels
- GaAs (200u and 62.5u) Module
- Fluro Module
- Built-in LED indicators



## 8. Bushing Monitoring Module

- 03 or 06 Channels
- Leakage Current
- Tan Delta / Power Factor
- Capacitance
- Phase Voltage
- Custom Tap Adaptor for Different Bushing



HF



UHF

## 9. Partial Discharge Module

- 04 or 08 Channels Continuous Monitoring
- Wide Range (HF and UHF)
- Sampling 100 MS/s
- Vertical Resolution 12bit
- Advanced PD Analysis
- UHF, Acoustic, Bushing PD Sensors available

## Technical Specifications

<b>POWER SUPPLY</b>	Input Power Requirement	24 - 48 V DC (Default), 120 W, and any other (upon request)
<b>CPU MODULE</b>	Data Storage Capacity	MicroSD external memory slot (up to 2 TB)
	Logging Rate	1 sec interval on USB
	Config port	USB (to use with Rugged connect windows software)
<b>SYSTEM CAPACITY</b>	Maximum number of Channels	Expandable to 256 Channels, Daisy chain up to 32 units (with Modbus, Canbus)
<b>FIBER OPTIC MODULES</b>	# of Channels	2, 4, 6 and 8 channels
	Measurement Range	-80 °C to +300 °C (cryogenic 4 °K range optional)
	Resolution	0.1 °C
	Accuracy	±1.0 °C (±0.2 °C in relative temperature)
	Scan Rate	200 ms / channel ( Optional: Faster scanning rates available)
<b>ANALOG INPUT MODULE</b>	# of Input Channels	05 or 10 Channels
	AC Current Input	Clamp-on CT with different ranges: 5Amp, 10Amp, 20Amp, 100Amp and others available
	DC Current Input	4 - 20 mA
	Temperature Input	100 ohm platinum (Pt100)
	Potentiometer	up to 20,000 ohms
<b>POWER MONITORING MODULE</b>	# of Input Channels	03 Current and 03 Voltage
	Current Input Range	0 - 5A
	Voltage Input Range	0 - 250V
	Sampling Rate	32 KS/s
	Measurement Parameters	Power, Through-Fault, Motor Torque etc.
<b>DIGITAL INPUT MODULE</b>	# of Input Channels	08 or 16 Channels
	Dry Contact	Resistance between the contact < 100 Ω
	Powered Contact	75 - 250Vdc
<b>ANALOG OUTPUT MODULE</b>	# of Input Channels	08 or 16 Channels
	Output format	4-20 mA or 0-5V or 0-10V Configurable for any measured / calculated value
<b>BUSHING MONITORING MODULE</b>	# of Input Channels	03 or 06 Channels
	Leakage Current Range	1mA to 200mA
	Monitoring Parameters	Tan Delta (PF), Capacitance, Phase Voltage
<b>PARTIAL DISCHARGE MODULE</b>	# of Input Channels	04 or 08 Channels
	Acquisition Bandwidth	HPM: 0.01 - 100Mhz UPM: 100 MHz - 2 GHz
	Monitoring Parameters	PD Amplitude, Discharge Rate and PRPD
<b>OUTPUT RELAY MODULE</b>	# of Output Channels	04 or 08 Form C relays



# CPM601-P

One Device for a wide range of assets and testing applications



**Rugged Monitoring presents most advanced Partial Discharge Monitor CPM601 to perform PD measurements in dual frequency range i.e., in the range of 0.01MHz - 100MHz as well as 300MHz - 2GHz.**

With the help of advanced electronics embedded inside CPM601, user can perform PD measurement using various sensors without the need of using external frequency down converters. This presents All-in-One solution to perform PD measurements using Acoustic, Ultrasonic, HFCT, TEV, Coupling Capacitors as well as UHF Sensors on all assets, GIS, Power Transformers, Rotating Machines and Power Cables.

CPM 601 is a Compact and sturdy enclosure with electronics making it portable, easy to carry, while enabling the user to perform PD measurements with less hassle. Monitor can directly transfer the data to PD Connect software installed on laptop else data can be temporarily stored (optional) in the device enabling the user to record PD pulses with higher sampling rate. Thousands of pulses per second can be transferred to the laptop enabling the user to generate fast and reliable Phase Resolved Partial Discharge (PRPD) graphs. PRPD patterns help the user to identify type of PD. CPM 601 and Software are packed with all necessary tools that help to perform effective PD measurements. Integrated variable amplifiers and onboard denoising features help during onsite testing in case of any huge noise.

We at Rugged Monitoring have a dedicated team for application specific customizations for sensors, monitor configuration and software integration to simplify data collection of testing and monitoring applications.

## Applications

- Online periodic partial discharge monitoring
- Online PD measurement during HV AC testing (Resonant test set, VLF, OWTS)
- Multiple point PD monitoring
- Cables and their accessories
- Rotating machines
- AIS/GIS switchgear/switchboards
- Power transformers

## Features

- Rugged, compact design
- Dual Frequency Ranges; 0.01MHz - 100MHz as well as 300MHz - 2GHz
- Compatible with Acoustic, Ultrasonic, HFCT, TEV, Coupling Capacitors as wells as UHF Sensors
- An interactive and comprehensive software PD Connect for reliable PD measurement and analysis
- Gigabit ethernet copper Cat5e communication link between monitor and laptop
- Optional rugged laptop with installed software suite
- IP65 rated

## Benefits

- Rugged sensors, monitor and laptop
- Gigabit ethernet communication between monitor and laptop
- Enhanced noise rejection
- Realtime denoising
- Software packed with useful tools for reliable and interactive PD measurements
- Robust recording and analytics
- Customizable according to customer specific applications
- Suitable for Online PD measurements

## Technical Specifications

<b>INPUT CHANNELS</b>	Channels	8 Multiplexed (4x HF and 4x UHF)
	Sampling Rate	250 MS/s
	Amplification	up to 50 dB, software selectable
	Filtering	Software configurable band pass filters
<b>HF CHANNELS</b>	Bandwidth	0.01 - 100 MHz
	Sensitivity	-50dBm
	Dynamic Range	50dB
<b>UHF CHANNELS</b>	Bandwidth	300 MHz - 2 GHz
	Sensitivity	-80 dBm
	Dynamic Range	70 Db
<b>DATA TRANSFER</b>	High Resolution (pulses data on simultaneous channels)	10,000 pulses per second for 4 simultaneous channels
	Low Resolution (pulse amplitude on simultaneous channels)	50,000 pulses per second for 4 simultaneous channels
	Transfer Rate	400 Mbps (depending on operating system and connection)
<b>MEMORY</b>	SSD	up to 1 TB (Optional)
<b>COMMUNICATION LINK</b>	Type	Ethernet Copper
	Cable	Cat5e
<b>SYNCHRONISATION INPUTS</b>	2 Inputs, software	Internal
	External	selectable
<b>IP RATING</b>	IP 65	
<b>TEMPERATURE RATING</b>	Ambient	-30°C - 60°C
	Storage	-40°C - 85°C
<b>POWER RATING</b>	Input Power	45 W
<b>DIMENSIONS</b>	260mm(L)x310mm(W)x120mm(H)	
<b>LAPTOP</b>	Rugged Laptop	(Optional)

## Ordering Code

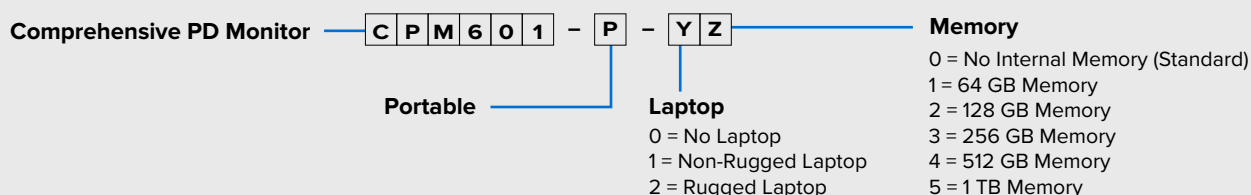

# HPM601-P High Frequency Partial Discharge Monitor



**Rugged design, designed for reliability, 3 Phase synchronous partial discharge monitoring equipment.**

Rugged Monitoring High Frequency Partial Discharge (PD) Portable Monitor is a compact and rugged device enabling the user to perform periodic offline and online PD measurements in power cables and accessories, switchgears and rotating machines. Compact size and rugged enclosure and electronics make it portable, easy to carry and enabling the user to perform PD measurements with less hassle.

Monitor is capable of transferring the data directly to Rugged Enterprise software installed on laptop or data can be temporarily stored (optional) in the device enabling the user to record PD pulses with higher sampling rate. Thousands of pulses per second can be transferred to the laptop enabling the user to generate fast and reliable Phase Resolved Partial Discharge (PRPD) graphs. PRPD patterns help the user to identify type of PD. Monitor and Software are packed with all necessary tools that help to perform effective PD measurements. Integrated variable amplifiers and on board denoising features help during onsite testing in case of presence of huge noise.

There is a dedicated team for application specific customizations for sensors, monitor configuration and software integration to simplify data collection of testing and monitoring applications.

## Applications

- Online periodic partial discharge monitoring
- Offline PD measurement during HV AC testing ( Resonant test set, VLF, OWTS)
- Multiple point PD monitoring
- Cables and their accessories
- Rotating machines
- AIS/GIS switchgear/switchboards
- Power transformers

## Features

- Rugged, compact design
- 4 synchronous input channels allow 3 phase synchronous measurement with additional external synchronous channel to enable the use of other type of sensor
- An interactive and comprehensive software Rugged Enterprise for reliable PD measurement and analysis
- Gigabit ethernet copper Cat5e communication link between monitor and laptop
- Optional rugged laptop with installed software suite IP65 rated

## Benefits

- Rugged sensors, monitor and laptop
- Gigabit ethernet communication between monitor and laptop
- Enhanced noise rejection
- Realtime denoising
- Software packed with useful tools for reliable and interactive PD measurements
- Robust recording and analytics
- Customizable according to customer specific applications
- Suitable for Online or Offline PD measurements

## Technical Specifications

<b>INPUT SIMULTANEOUS CHANNELS</b>	Channels	4 simultaneous channels 8 & 12 channel options available with multiplexer
	Sampling Rate	250 MS/s
	Bandwidth	0.01-100 MHz
	Amplification	up to 50 dB, software selectable
	Filtering	Software configurable band pass filters
<b>MEMORY</b>	SSD	up to 1 TB (Optional)
<b>DATA TRANSFER</b>	High Resolution (Pulses data on simultaneous channels)	10,000 pulses per second for 4 simultaneous channels
	Low Resolution (Pulse amplitude on simultaneous channels)	50,000 pulses per second for 4 simultaneous channels
	Transfer Rate	400 Mbps (depending on operating system and connection)
<b>COMMUNICATION LINK</b>	Type	Ethernet Copper or Fiber (100/1000 BASE-T)
	Connector	RJ45 or LC Multi-mode
<b>TEMPERATURE RATING</b>	Ambient	-30°C - 60°C
	Storage	-40°C - 85°C
<b>POWER RATING</b>	Input Power	240-100Vac, 45W
<b>SYNCHRONISATION INPUTS</b>	2 Inputs, software	Internal & External
	IP Rating	IP65
<b>DIMENSIONS</b>	260mm(L)x310mm(W)x120mm(H)	
<b>SOFTWARE</b>	Rugged Enterprise	

## Ordering Code

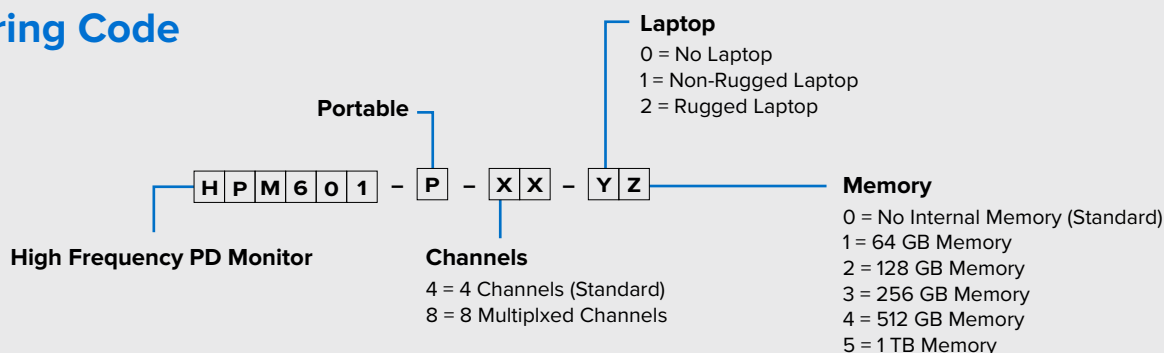

# UPM601-C High Frequency Partial Discharge Monitor



**Rugged design, designed for reliability, 3 Phase synchronous partial discharge monitoring equipment.**

"Rugged Monitoring Ultra High Frequency Partial Discharge (PD) monitoring solution is a platform that enables HV asset owners to keep monitoring PD due to insulation defects 24/7. System can also be used to perform online PD measurement during HV AC testing . Compact size and rugged enclosure of

monitor make it easy to get installed and get started. Solution can communicate with its user over IEC61850 or using Rugged Monitoring proprietary Rugged Enterprise software suite. System simple design enables it to get interfaced to third party protocols.

Each Monitor is capable of transferring data directly to Rugged Enterprise software installed on Server or data can be temporarily stored in the device in case of communication loss between server and monitor. Thousands of pulses persecond can be transferred to the Server enabling the user to generate fast and reliable Phase Resolved Partial Discharge (PRPD) graphs. PRPD graphs help the user to identify type of PD in HV assets. Monitoring solution is packed with all necessary tools that help to perform active PD measurements. Integrated variable amplifiers and on board denoising features help during onsite testing even in case of presence of huge noise.

There is a dedicated team for application specific customizations for sensors, monitor configuration and software integration to simplify cable data collection of testing and monitoring applications.

## Applications

- Online continuous partial discharge monitoring
- Online PD measurement during HV AC testing
- Multiple point PD monitoring
- Power Transformer
- Gas Insulated Switchgear (GIS)
- Circuit Breakers
- Cable Terminations

## Features

- Rugged, simple design
- 4 synchronous input channels allow 3 phase synchronous measurement with additional external synchronous channel to enable the use of other type of sensor
- Rugged Enterprise, a complete software suite for analysing the data and generating reports
- Indicator LEDs to alert in case of PD alarm or warning
- Gigabit ethernet copper Cat5e or multimode fiber communication link between monitor and server IP65 rated

## Benefits

- Rugged sensors, monitor and server
- Gigabit ethernet communication between monitor and server
- Robust design
- Each device is rigorously tested
- PD measurements
- Software packed with useful tools for reliable and interactive
- Robust recording and analytics
- Customizable according to customer specific applications
- Suitable for online or online PD measurements

## Technical Specifications

<b>MONITOR</b>	Channels	4 simultaneous channels
	Sampling Rate	250 MS/s
	Bandwidth	300Mhz - 2000 MHz
	Amplification	up to 50 dB, software selectable
	Filtering	Software configurable band pass filters
<b>MEMORY</b>	SSD	upto 256 GB (Optional)
<b>DATA TRANSFER</b>	High Resolution (Pulses data on simultaneous channels)	10,000 pulses per second for 4 simultaneous channels
	Low Resolution (Pulse amplitude on simultaneous channels)	50,000 pulses per second for 4 simultaneous channels
	Transfer Rate	400 Mbps (depending on operating system and connection)
<b>COMMUNICATION LINK</b>	Type	Ethernet Fiber / Copper
	Cable	Multimode Fiber / Cat5e
	IP Rating	IP65
<b>TEMPERATURE RATING</b>	Ambient	-30°C - 60°C
	Storage	-40°C - 85°C
<b>POWER RATING</b>	Input Power	35 W max
<b>SYNCHRONISATION INPUTS</b>	2 Inputs, software	Internal & xternal
<b>DIMENSIONS</b>	260mm(L)x310mm(W)x120mm(H)	
<b>SOFTWARE</b>	PD Live and Rugged Enterprise	
<b>REMOTE COMMUNICATION</b>	IEC61850 (Optional) Proprietary Rugged Connect for remote communication Customized third party interface on request	

## Ordering Code

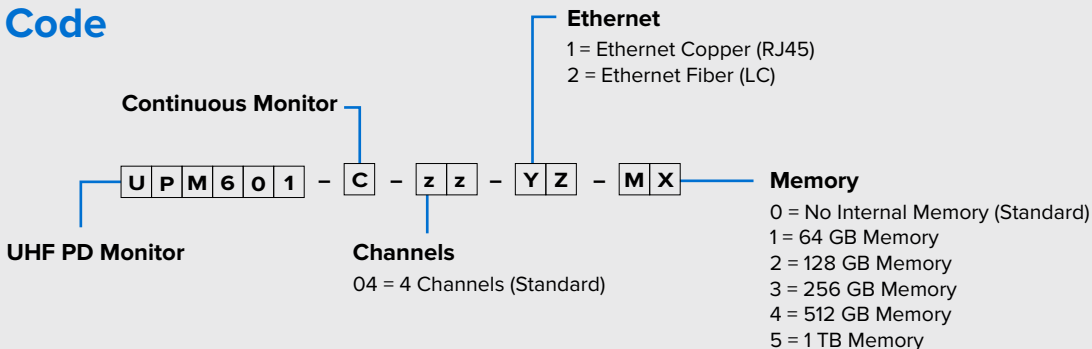

# PD211

## Rugged Partial Discharge Monitoring Module for OEMs



**Rugged Monitoring PD211 is a compact design, designed for reliable Partial Discharge (PD) Monitoring Module for Transformers, Switchgears, GIS and Power Cable Terminations.**

PD211 is based on the UHF (Ultra High Frequency) technology for PD signal acquisition and analysis. The Monitor is a combination of reliability and user-friendly configuration software. It has two variants with 04 channel and 08 channels, that can connect to 4 and 8 UHF-PD sensors respectively. The system can be integrated with any UHF PD sensors that are having response between 100MHz to 2000MHz.

The PD211 connects to the UHF PD sensors installed at the MV/HV assets. It measures the Ultra High Frequency (UHF) signals emitted by the PD Faults in HV/MV assets. The UHF signals are then analyzed for PD activity and categorization of Internal PD, External PD and Noise Signals. Internal PD signals are captured and stored for further analysis such as PRPD, PD Amplitude, Discharge Rate and trending. The PD amplitude and discharge rate is sent to the third-party system via Modbus (RTU) protocol using built-in serial (RS-485) port. The PRPD data is stored into the module and sent to third party system via CANBUS protocol using built-in CAN port.

### Applications

- Online continuous partial discharge monitoring
- Online PD measurement during HV AC testing
- Multiple point PD monitoring
- PD monitoring in Transformer using UHF PD Sensors
- PD Monitoring in GIS using UHF PD Sensors
- PD Monitoring in MV Switchgear using UHF PD Sensors
- PD Monitoring in Power Cables Terminations UHF PD Sensors

### Benefits

- Suitable for OEM-type applications (TMS, Gateways)
- Multiple mounting options - Din-Rail and Direct (Bare-board)
- Cost optimized solution for Partial Discharge monitoring
- Software designed for integration into monitoring systems /gateways
- Robust datalogging and Analytics
- Customizable according to customer specific applications
- Most accurate PD analysis with advanced noise gating
- Highly robust and safe monitoring systems

## Technical Specifications

Number of Channels	04 or 08 (Simultaneous acquisition, No Multiplexing)
Sampling Rate	125 Ms/s
Acquisition Bandwidth	300Mhz - 2000Mhz
Vertical Resolution	12-Bit
PD Sensitivity	-80dBm
Noise Elimination	
- Bad Pass Filters	Tuneable for different frequencies including but not limited to 440Mhz, 800Mhz, 1100Mhz, and 1600Mhz
- Software Noise Gating	Advanced denoising algorithms
Data Storage (Memory)	MicroSD external memory slot (Up to 2 TB)
Compatible PD Sensors	Any Ultra High Frequency (UHF) PD Sensors with sensitivity 100Mhz - 2000MHZ.
Synchronization Inputs	2 Inputs (Internal and External)
Serial Port	RS-485 with Modbus RTU and Can Port with CANBUS protocol
Configuration Port	Ethernet Port for configuration
Operating Temperature	-30 to 75 °C
Storage Temperature	-40 to 85 °C
Dimensions	4.92" x 4.92" x 1.89" (125mm x 125mm x 48mm)
Humidity	95% Non Condensing
Power Input	12 - 24V DC ( Default)
Power Consumption	15W
# of Relays Outputs	01 x Fail Safe Relay for System Failure

## Ordering Code

Number of Channels  
 04 = 4 Channels;  
 08 = 8 Channels

P D 2 1 1 - [ ] [ ]

M x

**Memory**

- 0 = No Internal Memory
- 1 = for 64GB Memory
- 2 = for 128GB Memory
- 3 = for 256GB Memory
- 4 = for 512GB Memory



# PD201 Rugged Partial Discharge Monitoring Module for OEMs



**The Rugged Monitoring PD201 is a compact design, designed for reliability Partial Discharge (PD) Monitoring Module for Transformers, Switchgears, Power Cables and Rotating Machines.**

PD201 combines accuracy and easy to use software. It has two variants, 04 channel and 08 channels, that can connect to 4 and 8 PD sensors respectively. The system can be integrated with wide range of PD sensors such as HFCT, TEV, Bushing Adaptors, Capacitive Couplers, Acoustic, and Ultrasonic PD sensors.

The PD201 connects to the HF PD sensors installed at the MV/HV assets. It measures the High Frequency (HF) signals emitted by the PD Faults in HV/MV assets. The HF signals are then analyzed for PD activity and Module categorizes pulses as Internal PD, External PD and Noise Signals. Internal PD signals are captured and stored for further analysis such as PRPD, PD Amplitude, Discharge Rate and trending. The PD amplitude and discharge rate is sent to the third-party system via Modbus (RTU) protocol using built-in serial (RS-485) port. The PRPD data is stored in the module and sent to third party system via CANBUS protocol using built-in CAN port.

## Applications

- Online continuous partial discharge monitoring
- Online PD measurement during HV AC testing
- Multiple point PD monitoring
- PD Monitoring in Transformer using Bushing
- Adaptors/Sensors
- PD Monitoring in Dry Type Transformers
- PD Monitoring in MV Switchgear using TEV / HFCT
- PD Monitoring in Power Cables using HFCT
- PD Monitoring in Generators and Motors using
- Capacitive Couplers and HFCT

## Features

- Rugged, Compact Design with multiple mounting options - Din-Rail, Direct
- 4 or 8 Synchronous Input Channels for monitoring Partial Discharge
- Monitors Partial Discharge into the Insulation of MV/HV assets
- Best in class EMI, ESD Immunity
- Modbus (Serial-RS485) and Canbus integration with third party systems
- Advance noise gating with built-in filters and software algorithms
- Built-In Fail Safe Relay for System Failure

## Benefits

- Suitable for OEM-type applications (TMS, Gateways)
- Multiple mounting options - Din-Rail and Direct (Bare-board)
- Cost optimized solution for Partial Discharge monitoring
- Software designed for integration into monitoring systems / gateways
- Robust datalogging and Analytics
- Customizable according to customer specific applications
- Most accurate PD analysis with advanced noise gating
- Highly robust and safe monitoring systems

## Technical Specifications

Number of Channels	04 or 08 (Simultaneous acquisition, No Multiplexing)
Sampling Rate	100 MS/s per channel
Acquisition Bandwidth	0.01 - 100Mhz
Vertical Resolution	12-Bit
Noise Elimination	
- Bad Pass Filters	User selectable integrated filters with 5Mhz to 25Mhz bandwidth range
- Software Noise Gating	Advanced denoising algorithms
Data Storage (Memory)	MicroSD external memory slot (Up to 2 TB)
Compatible PD Sensors	Any High Frequency (HF) PD Sensors (Bushing Adaptors, HFCT, TEV, Capacitive Couplers, Acoustic, Ultrasonic etc.)
Synchronization Inputs	2 Inputs (Internal and External)
Serial Port	RS-485 with Modbus RTU and Can Port with CANBUS protocol
Configuration Port	Ethernet Port for configuration
Operating Temperature	-30 to 75 °C
Storage Temperature	-40 to 85 °C
Dimensions	4.92" x 4.92" x 1.89" (125mm x 125mm x 48mm)
Humidity	95% Non Condensing
Power Input	12 - 24V DC (Default)
Power Consumption	15W
# of Relays Outputs	01 x Fail Safe Relay for System Failure

## Ordering Code

Number of Channels  
04 = 4 Channels;  
08 = 8 Channels

P D 2 0 1 - [ ] [ ]

[ M ] x [ ] **Memory**

0 = No Internal Memory  
1 = for 64GB Memory  
2 = for 128GB Memory  
3 = for 256GB Memory  
4 = for 512GB Memory

# HSENS-H

Provides automated continuous partial discharge monitoring

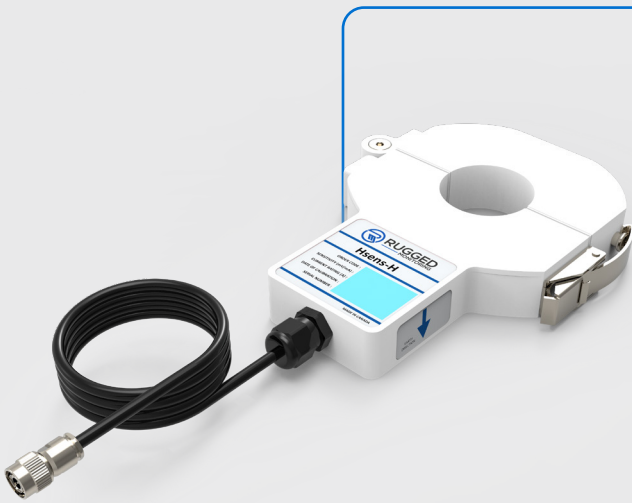

- High Frequency Current Transformer
- Rugged, reliable design
- IP65 rated
- Split core design for easy installation
- Transient overvoltage protection integrated inside Sensor
- Different options of internal diameter dimensions
- RG223 high noise immunity cable
- TNC connector for reliable connection

Hsens-H is a High Frequency Current Transformer sensor. It is a split core and an inductive type of sensor that can be clamped around the earth (ground) shield to measure PD signals. Based on power cable termination condition, an HFCT sensor can also be clamped around cable insulation without earth shield or around the cable with earth shield looped back for the purpose of PD measurements. For HFCT clamped around the cable insulation without earth shield or cable with earth shield looped back, high current variant can be used for rated load current of cable.

Sensor is IP65 rated and features integrated transient overvoltage protection inside sensor. Transient protection will help in minimizing transients that can be expected during PD monitoring

## Applications

- Online periodic partial discharge monitoring
- Online PD measurement during HV AC testing
- Multiple point PD monitoring
- Cables, joints and terminations
- Rotating machines
- AIS/GIS switchgear
- Power transformers

## Benefits

- Transient overvoltage protected
- Noise immunity
- IP65 rated
- Rigorously tested
- Split core for easy installation
- Stainless steel robust latch to keep split core closed
- Customizable according to customer specific applications
- Suitable for Online or Online PD measurements

## Technical Specifications

<b>SENSOR</b>	Type	Split core
	Frequency Response (-6dB):	100 kHz - 25 MHz
	Material	Rugged Plastic (Black), other options available
	Current Ratings	50A, other options available
<b>MODELS</b>	HFCT-3	220mm (L) x 118mm (W) x 33mm (H) (ID = 30mm)
	HFCT-5	220mm (L) x 163mm (W) x 28mm (H) (ID = 50mm)
	HFCT-9	265mm (L) x 200mm (W) x 38mm (H) (ID = 90mm)
	HFCT-14	330mm (L) x 275mm (W) x 38mm (H) (ID = 140mm)
<b>SIGNAL CABLE</b>	Connectors	RG223
	Type	Cable Gland (Sensor End) and TNC connector (Monitor End), other options available
	Cable Length	5m, other options available
<b>IP RATING</b>	IP65	
<b>TEMPERATURE</b>	Ambient	-30 °C – 70 °C
	Storage	-30 °C – 70 °C
	Customization	For any different requirement, please consult

## Ordering Code

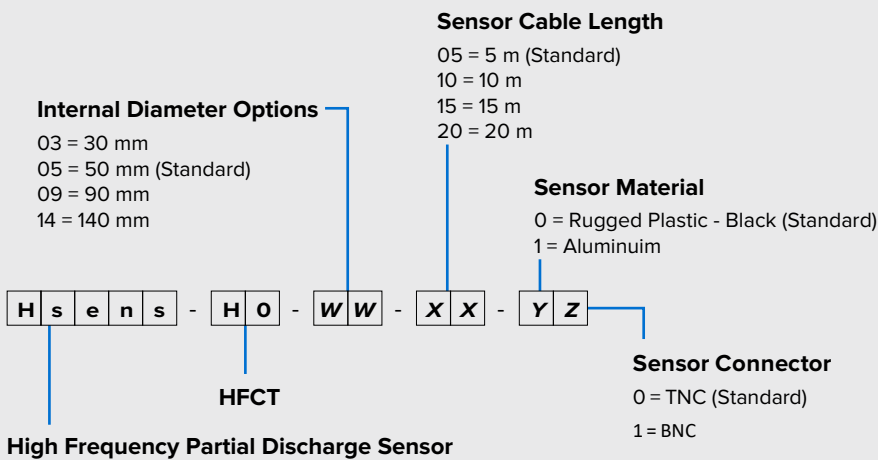

# HSENS-T Sensors for Switchgear, Cable termination, Breaker, Motor



- **Transient Earth Voltage Sensor**
- **Rugged, compact design**
- **Strong magnets to attach sensor**
- **IP65 rated**
- **Transient overvoltage protection**
- **integrated inside Sensor**
- **RG223 high noise immunity cable**
- **TNC connector for reliable connection**

Hsens-T is a Transient Earth Voltage Sensor that can be used to detect external partial discharges inside metal clad switchgear or power cables termination box of rotating machines and power transformers. An application of HFCT along with TEV can help in PD diagnostic and confirmation of internal versus external PD.

Sensor is IP65 rated and features integrated transient overvoltage protection inside sensor. Transient protection will help in minimizing transients that can be expected during PD monitoring.

TEV sensor has strong magnets that help it to attach to the walls of metal clad switchgear. TEV forms a capacitive coupling with grounded metal switchgear to detect transients of external PD happening inside metal clad switchgear at termination

## Rugged design, IP65 rated, overvoltage protected, PD measurement at Cables (and their accessories), Switchgears, Rotating Machines and Power Transformers

### Applications

- Online periodic partial discharge monitoring
- Online PD measurement during HV AC testing
- Multiple point PD monitoring
- Cables, joints and terminations
- Rotating machines
- AIS/GIS switchgear
- Power transformers

## Benefits

- Rugged sensors
- Noise immunity
- IP65 rated
- Rigorously tested
- Transient overvoltage protected
- Strong magnets to help sensor attach
- Customizable according to customer specific applications
- Suitable for Online or Online PD measurements

## Technical Specifications

<b>SENSOR</b>	Type	Integrated magnets help it to attach to metal clad switchgear
	Frequency Response (-6dB):	1 MHz - 100 MHz
	Material	Rugged Plastic (Black), other options available
<b>SIGNAL CABLE</b>	Type	RG223
	Connectors	Cable Gland (Sensor End) and TNC connector (Monitor End), other options available
	Cable Length	5m as standard, other options available
<b>IP RATING</b>	IP65	
<b>TEMPERATURE</b>	Ambient	-30 °C – 70 °C
	Storage	-40 °C – 85 °C
<b>DIMENSIONS</b>	70mm (L) x 70mm (W) x 33 mm (H)	
<b>CUSTOMIZATION</b>	For any different requirement, please consult	

## Ordering Code

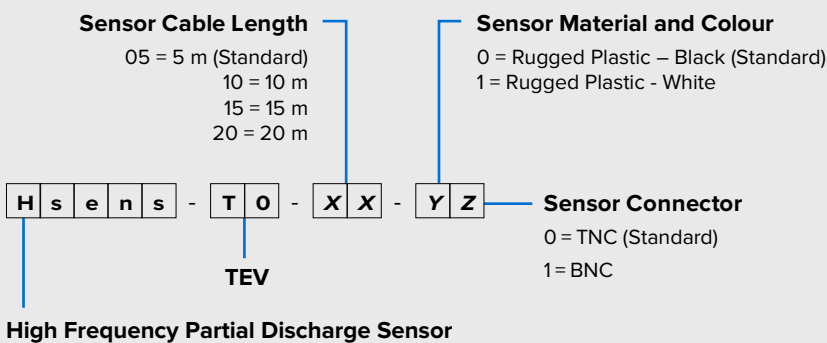

# USENS-C PARTIAL DISCHARGE SENSOR



- Rugged, reliable design
- IP65 rated
- Transient overvoltage protection
- Easy to Install
- Different options of internal diameter dimensions

USENS-C is Ultra High Frequency (UHF) PD sensor for Power cables, Switchgears. The sensor can be installed directly on the power cable and switchgears.

The IP65 rated Sensor has integrated transient overvoltage protection inside. Transient protection will help in minimizing transients that can be expected during PD monitoring.

## Ultra High Frequency PD sensors for Cables and switchgears

### Applications

- Online periodic partial discharge monitoring
- Online PD measurement during HV AC testing
- Multiple point PD monitoring

### Benefits

- Transient overvoltage protected
- Noise immunity
- IP65 rated
- Rigorously tested

### Ordering Code

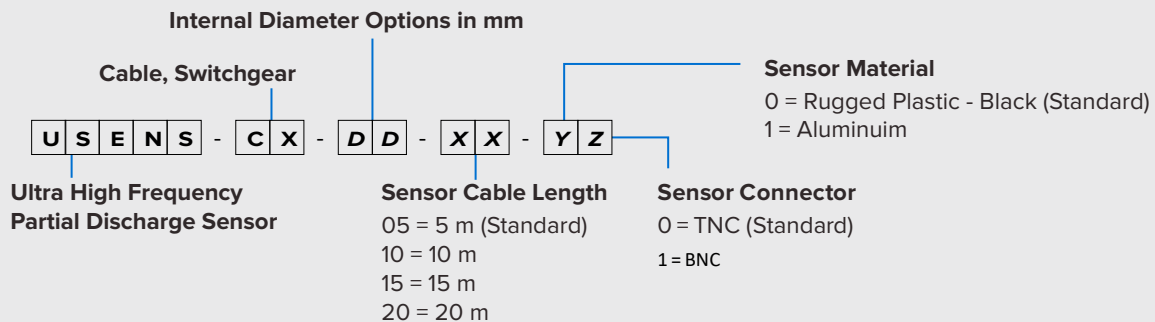

## Technical Specifications

Frequency Response	30MHz - 1GHz
Sensitivity	up to -70 dBm
Withstand Voltage	up to 1500 kV
Output	N-Type connector; Customized option available
Connector Circuit Impedance	50Ω
Vibration Testing	Suitable for HV - GIS and Transformer applications
Ingress Protection (IP)	IP-65
Ambient (Operating Temperature)	-60 °C to +100 °C
Storage Temperature	-60 °C to +100 °C
Operating Humidity	95% humidity at 50 °C
Dimensions	Customized as per customer requirements
Weight	Customized as per customer requirements
Install Position	Power Cables, Terminations, Switchgears, Rotating Machines
Signal Cable	Very low attenuation UHF (Coax) cable



# CTCLAMP

## CLAMP-ON Current Transformer



### CTCLAMP-D19 SERIES

Split-core current transformer for the measurement of AC currents from 1 to 200Amps. The Clamp-On CT easily snaps around the conductor and ideal for installation on electrical wiring. It has output in voltage form, 0.333V that is proportional to the RMS value of the primary current.

## Applications

- **Transformer Monitoring:**  
Current measurement for Transformer Load current, Fan Motor Current, Pump Motor Current, OLTC Motor Current
- **Switchgear/Breaker Monitoring:**  
Current measurement for Phase Current, Motor Current, Heater Current (AC)
- **Automation and Control:** Current measurement for protection systems

## Benefits

- High isolation between primary and secondary circuits
- Compact design, Plug and Play
- Cost-Effective Solution for variety of applications
- High accuracy and durable
- UL Recognized
- CE and RoHS complaint

## Avialable Options

Model #	Measuring Current Rating (Conductor)
CLCLAMP-19-50A	Up to 5 Amp
CLCLAMP-19-10A	Up to 10 Amp
CLCLAMP-19-30A	Up to 30 Amp
CLCLAMP-19-50A	Up to 50 Amp
CLCLAMP-19-70A	Up to 70 Amp
CLCLAMP-19-100A	Up to 100 Amp
CLCLAMP-19-150A	Up to 150 Amp
CLCLAMP-19-200A	Up to 200 Amp

Technical Specifications

Input Current	1 Amp to 200 Amp
Input Current Frequency	50 Hz to 400 Hz
Output at rated current	0.333 Volt AC
Accuracy	± 1% (at 10% to 130% of rated current)
Phase angle	< 2 degrees measured at 50% rated current
Operating Temperature	-20 °C to + 85 °C
Storage Temperature	-20 °C to + 85 °C
Protection Degree	IP40
Sensor Cable Length	2m Twisted Pair (Default). Longer cables available on demand

Drawing and Dimensions

